



## About us

### MARAVIĆ INŽENJERING I KONSTRUKCIJE d.o.o.

"MARAVIĆ INŽENJERING I KONSTRUKCIJE d.o.o." or shortened MARING d.o.o. is company specialized in the production and sales of boiler manifolds for heating systems. MARING has been present for many years on the domestic and foreign markets with a clear business policy, production-sales and development strategy, and a renown reputation in industry. All products are recognizable by their unique MIK logo and protected octagonal shape.



The company has been founded in 1989 in Nedelišće from the already existing craft "MARAVIĆ INSTALACIJE I KLIMA", which had been doing business since 1980. Since 1984, the company emphasis has been put on foreign markets in the range of 40% of total production. The company's export orientation is continuously increasing, so its share of foreign sales revenue in the period from 2016 until 2018 amounted to an average of 93%.

Demand for MIK manifolds has been increasing over the years, becoming more and more present in the countries of EU, People's Republic of China, Russia and our neighbouring countries. Continuous growth of production has been accompanied by increased quality control. Quality of our products has been our imperative and we are certain that this is a guarantee of our success. Our long-lasting quality in business is proven by norms ISO 9001:2015 and ISO 14001:2015.

Our assortment includes series-made products, but also products according to specific customer requirements. In addition, we provide a 5 year warranty on all our products.

Feel free to contact our expert team with confidence, as we are certain that we are fully capable to offer you quality solutions with short delivery terms at very competitive prices.

The owner, Dmtitar Maravić



MARING d.o.o. - view from above

## Automated production processes

### MANAGEMENT SYSTEM CERTIFICATE

Certificate No.: 1500120190446  
Initial certification date: 08. October, 2019  
Valid: 08. January, 2018 - 03. February, 2022

This is to certify that the management system of

**MARAVIĆ INŽENJERING I KONSTRUKCIJE d.o.o.**  
Zagrebačka 38, 40000, Čakovec, Croatia

has been found to conform to the Quality Management System standard:  
**ISO 9001:2015**

This certificate is valid for the following scope:  
**Production of water distribution manifolds and equipment for central heating**

Place and date:  
Zagreb, 06. September, 2018



For the issuing office:  
DNV GL - Business Assurance  
Buzinski put 32, 10010, Zagreb, Croatia

Milena Stjepić

Lack of full set of conditions as set out in the Certification Agreement may render this Certificate invalid.  
www.dnvgl.com | www.dnvgl.com/certification | www.dnvgl.com/assurance | www.dnvgl.com/quality | www.dnvgl.com/energy



### MANAGEMENT SYSTEM CERTIFICATE

Certificate No.: 1500120190446  
Initial certification date: 07. September, 2018  
Valid: 07. September, 2018 - 04. September, 2023

This is to certify that the management system of

**MARAVIĆ INŽENJERING I KONSTRUKCIJE d.o.o.**  
Zagrebačka 38, 40000, Čakovec, Croatia

has been found to conform to the Environmental Management System standard:  
**ISO 14001:2015**

This certificate is valid for the following scope:  
**Production of water distribution manifolds and equipment for central heating**

Place and date:  
Zagreb, 17. September, 2018



For the issuing office:  
DNV GL - Business Assurance  
Buzinski put 32, 10010, Zagreb, Croatia

Milena Stjepić

Lack of full set of conditions as set out in the Certification Agreement may render this Certificate invalid.  
www.dnvgl.com | www.dnvgl.com/certification | www.dnvgl.com/assurance | www.dnvgl.com/quality | www.dnvgl.com/energy

We own the latest galvanizing technology with zinc flakes  
fZn-nc-480h according to DIN EN ISO 10683:

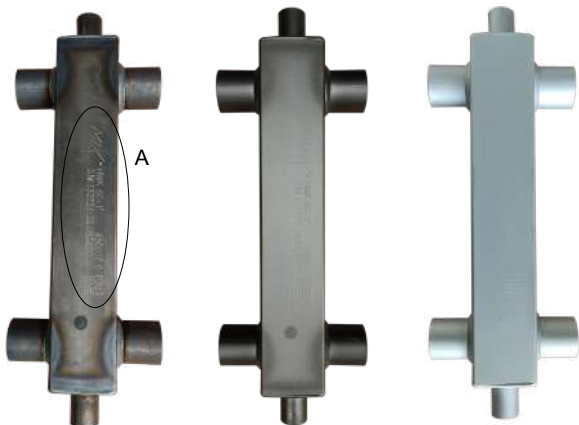

Detail A: stamped markings on steel chamber:



Unique serial number and date of manufacture  
are clearly marked on the products



**MIK boiler manifolds:**

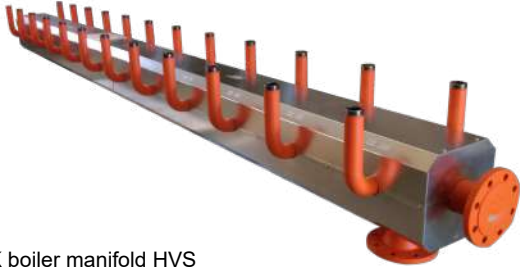

MIK boiler manifold HVS



MIK boiler manifold HVI with thermally separated chambers



MIK boiler manifold HVI with galvanised sheet steel jacket and vapour barrier insulation



MIK boiler manifold HV

**Boiler room with built-in MIK equipment:**

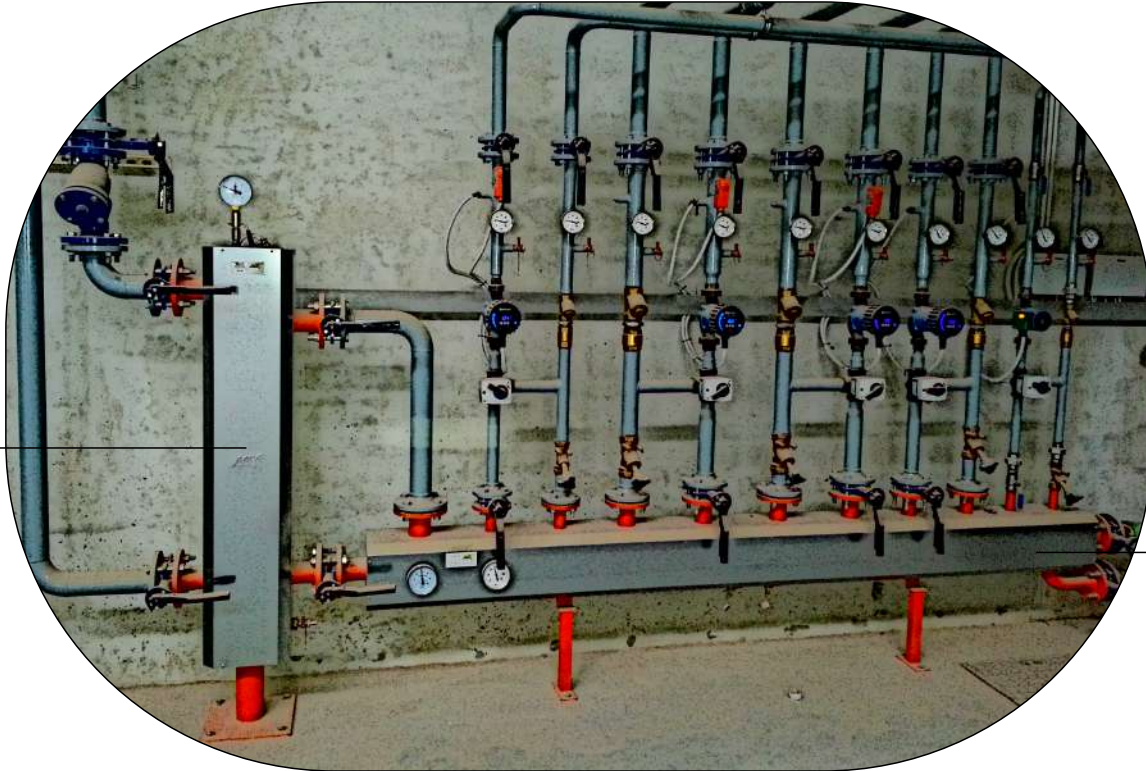

**MIK hydraulic separators:**



MIK hydraulic separator HW without cleaning aperture



MIK hydraulic separator HW R with cleaning aperture

**Boiler room with vapor barrier insulation:**





# Content

<b>MIK EQUIPMENT DN25 - 50 kW</b>	Equipment example - DN25 - 50 kW		6	
	Boiler manifolds - DN25 - 50 kW	HV 60/125	8	
		HV 60/125 SG	9	
		HVI	10	
	Hydraulic separators - DN25 - 3 m <sup>3</sup> /h	HWK 60-1"	11	
		HW 60/125-1"	11	
		HW 60/250	12	
		HW 60	12	
	Heating circuit modules - DN25	HK 25-2	13	
		HK 25-3	14	
	Equipment for heating/cooling systems - DN25 - 50 kW		15	
	<b>MIK EQUIPMENT DN32 - 75 kW</b>	Equipment example - DN32 - 75 kW		18
		Boiler manifolds - DN32 - 75 kW	HV 70/125	19
		Hydraulic separators - DN32 - 3 do 4 m <sup>3</sup> /h	HWK 60-1 ¼"	20
			HW 60/125-1 ¼"	20
HW 60/375			21	
HW 60/375A			21	
Heating circuit modules - DN32		HK 32-2	22	
		HK 32-3	23	
Equipment for heating/cooling systems - DN32 - 75 kW			24	
<b>MIK EQUIPMENT DN32 - 90 kW</b>		Equipment example - DN32 - 90 kW		26
	Boiler manifolds - DN32 - 90 kW	HV 90/125	27	
		HVI 90/125	28	
	Hydraulic separators - DN32 - 4 m <sup>3</sup> /h	HW 60/375 OF	29	
	Equipment for heating/cooling systems - DN32 - 90 kW		30	
	<b>MIK EQUIPMENT DN40 - 120 kW</b>	Boiler manifolds - DN40 - 120 kW	HV 80/200	31
HV 80/200 SU			32	
HV 80/125/190 DN25			33	
Hydraulic separators - DN40 - 7 m <sup>3</sup> /h		HW 80/190-1 ½"	34	
		HW 80/200-1 ½"	34	
		HW 80/400	35	
		HW 80	35	
Equipment for heating/cooling systems - DN40 - 120 kW			36	
<b>MIK EQUIPMENT DN50 - 165 kW</b>		Equipment example - DN50 - 165 kW		37
		Boiler manifolds - DN50 - 165 kW	HV 80/125	38
	Hydraulic separators - DN50 - 8m <sup>3</sup> /h	HW 80/570	39	
		HW 80/570A	39	
	Equipment for heating/cooling systems - DN50 - 165 kW		40	
<b>Insulations display</b>	Display example of insulation for heating and insulation for cooling		41	
<b>CUSTOM PRODUCTS</b>	Custom boiler manifolds	Boiler manifolds HV	42	
		Boiler manifolds HVI	44	
		Boiler manifolds HVE	46	
	Custom hydraulic separators	Hydraulic separators HW	48	
	<b>News</b>	News		50

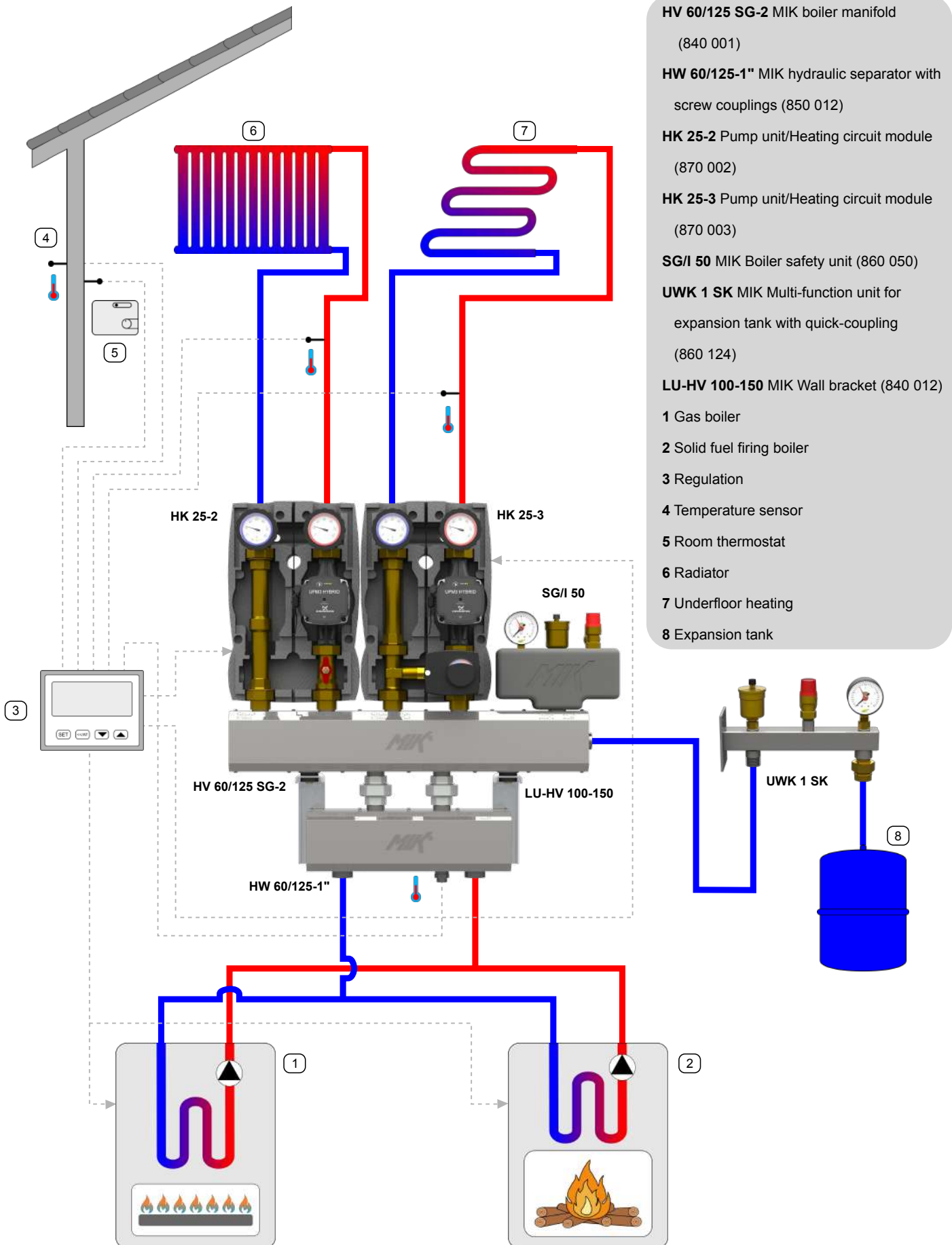

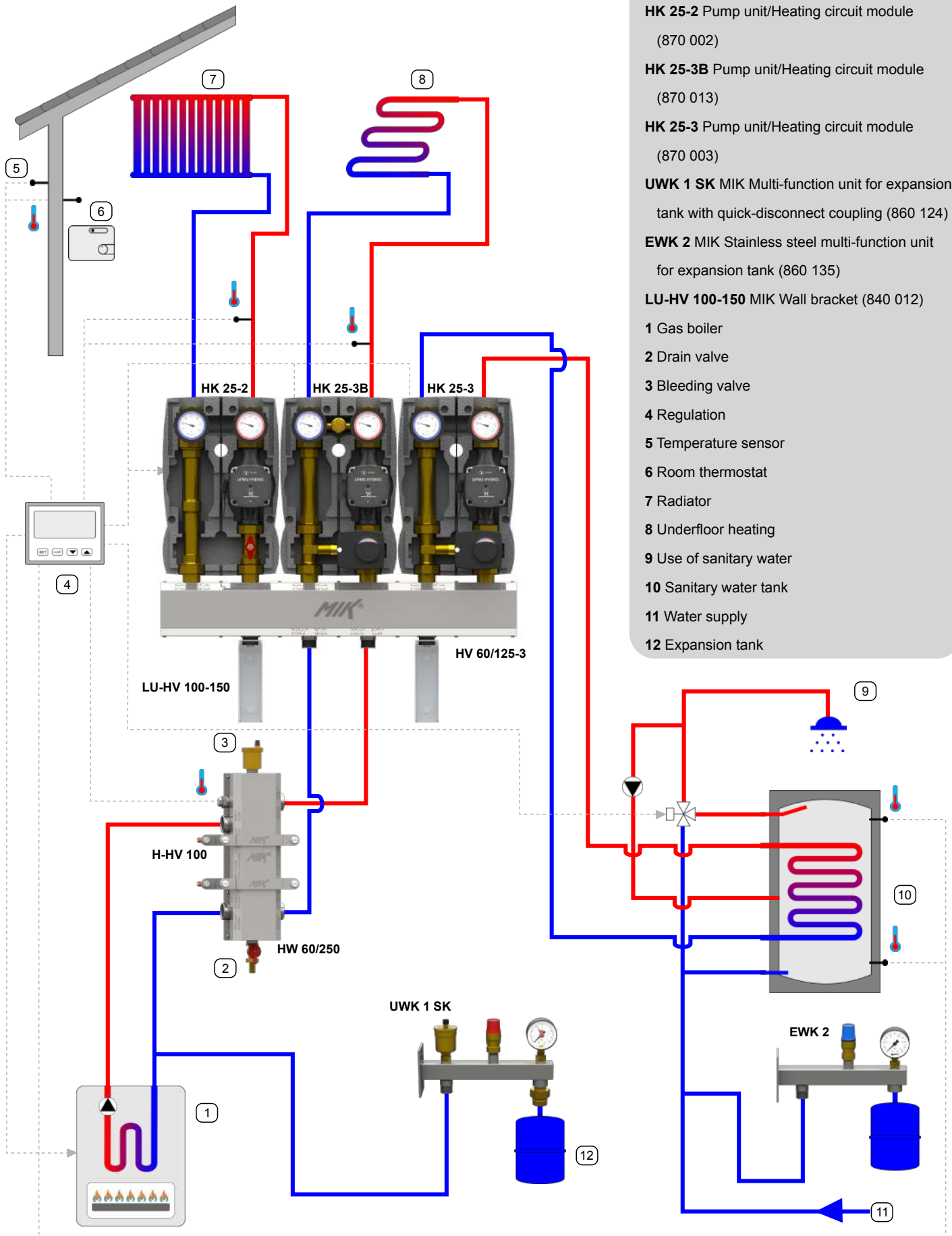

## Combined supply-return manifold HV 60/125

Up to 50 kW output at a temperature difference 20 °C and flow rate 2,3 m<sup>3</sup>/h

- 2 to 6 heating/cooling circuits
- Boiler connections underneath
- Consumer connections above
- Supply and return connections located side by side
- Compact construction with integrated supply and return
- Material: S235 carbon steel
- Zinc flake coated chambers flZn-nc-480h acc. DIN EN ISO 10683
- Insulation for heating or cooling with 0,6 mm galvanised sheet steel jacket
- Supply and return markings stamped into sheet steel jacket



- Supply
- Return

\*Insulations display example on Page. 41

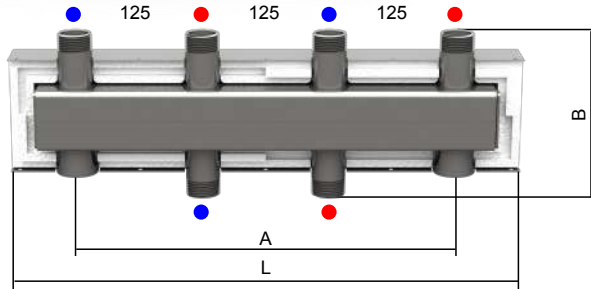



### Technical specification

Boiler connections	external thread R 1"
Consumer connections	external thread R 1"
Insulation <sub>Heating</sub>	EPS 25 mm (EN 13501-1 E)
Insulation <sub>Cooling</sub>	FEF 19 mm (EN 13501-1 B,s3, d0)
Max. working temperature <sub>EPS</sub>	90 °C
Max. working temperature <sub>FEF</sub>	85 °C
Max. working pressure	6 bar
K <sub>vs</sub> value	20,9
Connections distance	125 mm
Installation height, B	165 mm
Insulation height	115 mm
Produced acc.	2014/68/EU

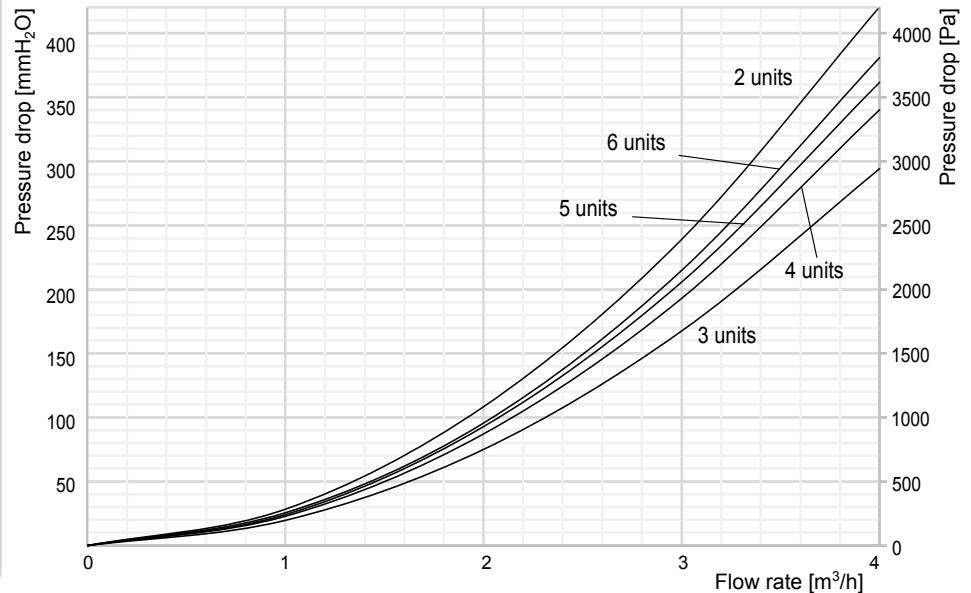
### Pressure drop diagram

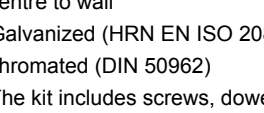
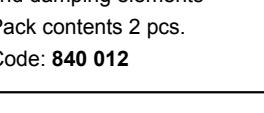

Type	Built-in length L [mm]	Offset of supports A [mm]	Consumer units	Code -heating*	Code -cooling*
 HV 60/125-2	506	375	2	<b>840 003</b>	<b>840 003 1</b>
 HV 60/125-3	756	375	3	<b>840 004</b>	<b>840 004 1</b>
 HV 60/125-4	1006	625	4	<b>840 005</b>	<b>840 005 1</b>
 HV 60/125-5	1256	625	5	<b>840 006</b>	<b>840 006 1</b>
 HV 60/125-6	1506	875	6	<b>840 014</b>	<b>840 014 1</b>

### MIK Wall bracket LU-HV 100-150

- 100 or 150 mm distance from manifold centre to wall
- Galvanized (HRN EN ISO 2081) and chromated (DIN 50962)
- The kit includes screws, dowels, washers and damping elements
- Pack contents 2 pcs.
- Code: **840 012**





## Combined supply-return manifold HV 60/125 SG

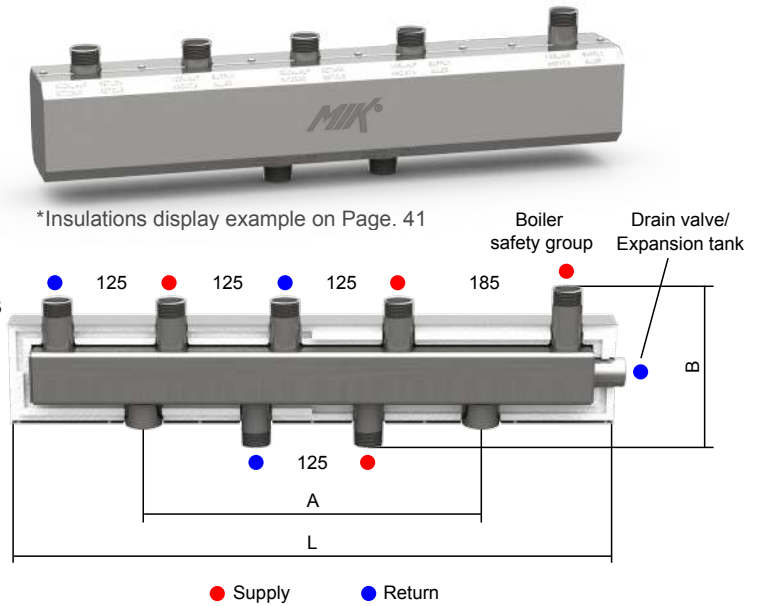

Up to 50 kW output at the temperature difference 20 °C and flow rate 2,3 m<sup>3</sup>/h

- 2 to 3 heating/cooling circuits
- Boiler connections underneath
- Consumer connections above
- Supply and return connections located side by side
- Compact construction with integrated supply and return
- Material: S235 carbon steel
- Zinc flake coated chambers flZn-nc-480h acc. DIN EN ISO 10683
- Insulation for heating or cooling with 0,6 mm galvanised sheet steel jacket
- Supply and return markings stamped into sheet steel jacket
- Boiler safety group connection
- Expansion tank/drain valve connection



### Technical specification

Boiler connections	external thread R 1"	Max. working temperature <sub>FEF</sub>	85 °C
Consumer connections	external thread R 1"	Max. working pressure	6 bar
Expansion tank/drain valve	internal thread G 3/4"	Connections distance	125 mm
Boiler safety group	external thread R 1"	Installation height, B	178 mm
Insulation <sub>Heating</sub>	EPS 25 mm (EN 13501-1 E)	Insulation height	115 mm
Insulation <sub>Cooling</sub>	FEF 19 mm (EN 13501-1 B,s3,d0)	Produced acc.	2014/68/EU
Max. working temperature <sub>EPS</sub>	90 °C	Pressure drop: for approximate data see HV 60/125	

Type	Built-in length L [mm]	Offset of supports A [mm]	Consumer units	Code -heating*	Code -cooling*
 HV 60/125 SG-2	670	375	2	<b>840 001</b>	<b>840 001 1</b>
 HV 60/125 SG-3	920	375	3	<b>840 002</b>	<b>840 002 1</b>

## MIK Wall bracket LU-HV 100-150

- 100 or 150 mm distance from manifold centre to wall
- Galvanized (HRN EN ISO 2081) and chromated (DIN 50962)
- The kit includes screws, dowels, washers and damping elements
- Pack contents 2 pcs.
- Code: **840 012**



## Combined supply-return manifold HVI

Up to 50 kW output at a temperature difference of 20 °C and flow rate of 2,3 m<sup>3</sup>/h

- 2 to 7 heating/cooling circuits
- Boiler connections underneath
- Consumer connections above
- Supply and return connections located side by side
- Compact construction with integrated supply and return
- Supply and return chambers thermally separated
- Material: S235 carbon steel
- Zinc flake coated chambers flZn-nc-480h acc. DIN EN ISO 10683
- Insulation for heating or cooling with 0,6 mm galvanised sheet steel jacket
- Supply and return markings stamped into sheet steel jacket



\*Insulations display example on Page. 41

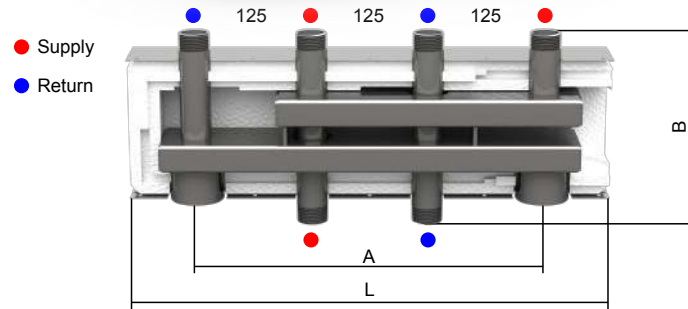

### Technical specification

Boiler connections	external thread R 1"
Consumer connections	external thread R 1"
Insulation <sub>Heating</sub>	EPS 35 mm (EN 13501-1 E)
Insulation <sub>Cooling</sub>	FEF 19 mm (EN 13501-1 B,s3,d0)
Max. working temperature <sub>EPS</sub>	90 °C
Max. working temperature <sub>FEF</sub>	85 °C
Max. working pressure	6 bar
K <sub>vs</sub> value	22,8
Connections distance	125 mm
Installation height, B	210 mm
Insulation height	155 mm
Produced acc.	2014/68/EU

Pressure drop diagram

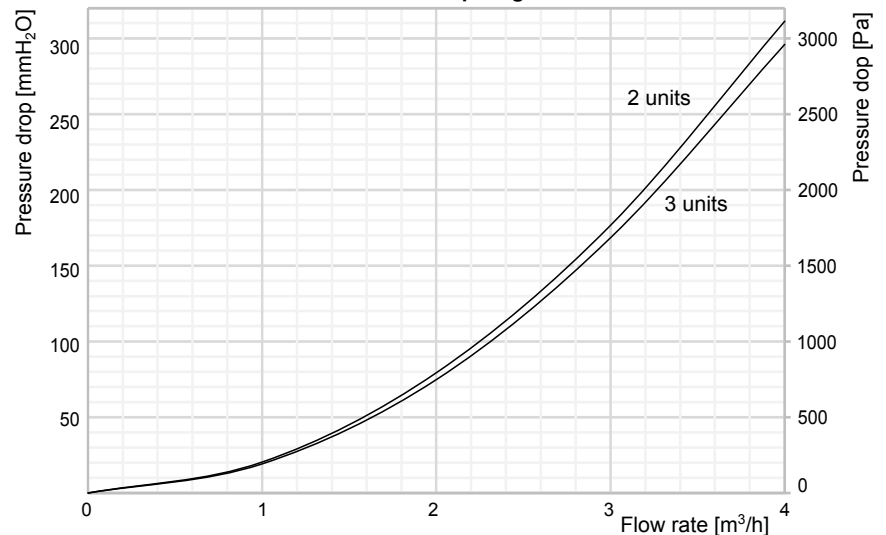

Type	Built-in length L [mm]	Offset of supports A [mm]	Consumer units	Code -heating*	Code -cooling*
HVI-2	520	375	2	<b>841 102</b>	<b>841 102 1</b>
HVI-3	770	375	3	<b>841 103</b>	<b>841 103 1</b>
HVI-4	1020	625	4	<b>841 104</b>	<b>841 104 1</b>
HVI-5	1270	625	5	<b>841 105</b>	<b>841 105 1</b>
HVI-6	1520	875	6	<b>841 106</b>	<b>841 106 1</b>
HVI-7	1770	875	7	<b>841 107</b>	<b>841 107 1</b>

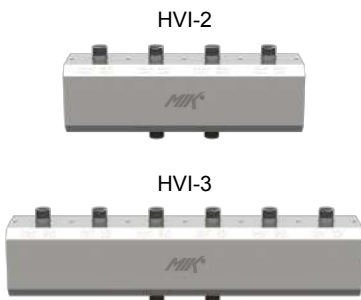

### MIK Wall bracket LU-HV 160-220

- 160 or 220 mm distance from manifold centre to wall
- Galvanized (HRN EN ISO 2081) and chromated (DIN 50962)
- The kit includes screws, dowels, washers and damping elements
- Pack contents 2 pcs.
- Code: **840 013**



## Hydraulic separator HWK 60-1"

Flow rates up to 3 m<sup>3</sup>/h

- Material: S235 carbon steel
- Zinc flake coated chamber flZn-nc-480h acc. DIN EN ISO 10683
- Insulation for heating or cooling with 0,6 mm galvanised sheet steel jacket
- Supply/return and boiler/consumer markings stamped into sheet steel jacket
- Bleeding and flushing/filling/emptying connections

### Technical specification

Boiler connections	internal thread G 1"
Consumer connections	internal thread G 1"
Insulation <sub>Heating</sub>	EPS 25 mm (EN 13501-1 E)
Insulation <sub>Cooling</sub>	FEF 19 mm (EN 13501-1 B,s3,d0)
Max. working temperature <sub>EPS</sub>	90 °C
Max. working temperature <sub>FEF</sub>	85 °C
Max. working pressure	6 bar
Volume	1,0 l
Bleeding	internal thread G ½"
Flushing/filling/emptying	internal thread G ½"

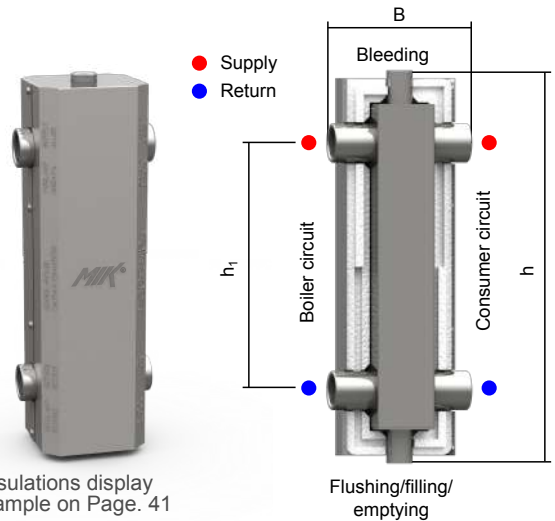

\*Insulations display example on Page. 41

Type	Built-in height h [mm]	Built-in width B [mm]	Distance of boiler and consumer connections <sub>1</sub> [mm]	Code -heating* -cooling*
HWK 60-1"	397	142	250	<b>850 007</b> <b>850 007 1</b>

## Hydraulic separator HW 60/125-1"

Flow rates up to 3 m<sup>3</sup>/h

- Material: S235 carbon steel
- Zinc flake coated chamber flZn-nc-480h acc. DIN EN ISO 10683
- Insulation for heating or cooling with 0,6 mm galvanised sheet steel jacket
- Supply/return and boiler/consumer markings stamped into sheet steel jacket
- Temperature sensor connection
- Equipped with two 1" union flat seat fittings



### Technical specification

Boiler connections	internal thread G 1"
Consumer connections	external thread R 1"
Insulation <sub>Heating</sub>	EPS 25 mm (EN 13501-1 E)
Insulation <sub>Cooling</sub>	FEF 19 mm (EN 13501-1 B,s3,d0)
Max. working temperature <sub>EPS</sub>	90 °C
Max. working temperature <sub>FEF</sub>	85 °C
Max. working pressure	6 bar
Volume	1,0 l
Temperature sensor	internal thread G ½"
Pressure drop at max. recirculation	< 1200 Pa



\*Insulations display example on Page. 41

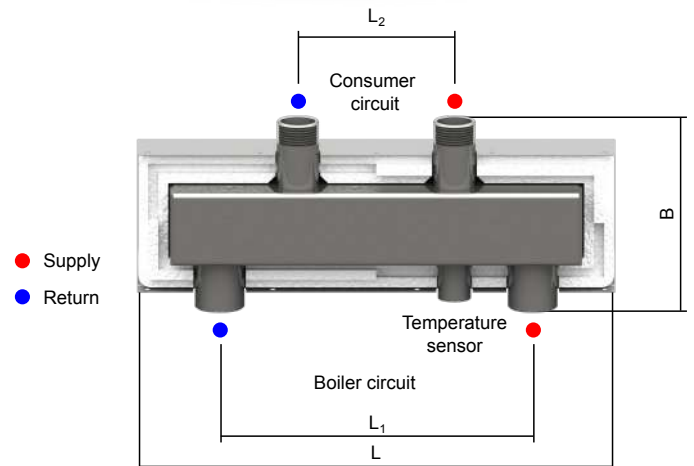

Type	Built-in length L [mm]	Built-in height B [mm]	Boiler connections distance L <sub>1</sub> [mm]	Consumer connections distance L <sub>2</sub> [mm]	Code -heating*	Code -cooling*
HW 60/125-1"	381	153,5	250	125	<b>850 012</b>	<b>850 012 1</b>

## MIK Wall brackets H-HV

- 100 or 150 mm distance from separator centre to wall
- Galvanized (HRN EN ISO 2081) and chromated (DIN 50962)
- The kit includes screws and dowels
- Pack contents 2 pcs.
- Code: **840 007** (100 mm)  
**840 008** (150 mm)



## Hydraulic separator HW 60/250

Flow rates up to 3 m<sup>3</sup>/h

- Material: S235 carbon steel
- Zinc flake coated chamber flZn-nc-480h acc. DIN EN ISO 10683
- Insulation for heating or cooling with 0,6 mm galvanised sheet steel jacket
- Supply/return and boiler/consumer markings stamped into sheet steel jacket
- Bleeding and flushing/filling/emptying connections
- Temperature sensor connection

### Technical specification

Boiler connections	internal thread G 1"
Consumer connections	internal thread G 1"
Insulation <sub>Heating</sub>	EPS 25 mm (EN 13501-1 E)
Insulation <sub>Cooling</sub>	FEF 19 mm (EN 13501-1 B,s3,d0)
Max. working temperature <sub>EPS</sub>	90 °C
Max. working temperature <sub>FEF</sub>	85 °C
Max. working pressure	6 bar
Volume	1,0 l
Bleeding	internal thread G ½"
Temperature sensor	internal thread G ½"
Flushing/filling/emptying	internal thread G ½"

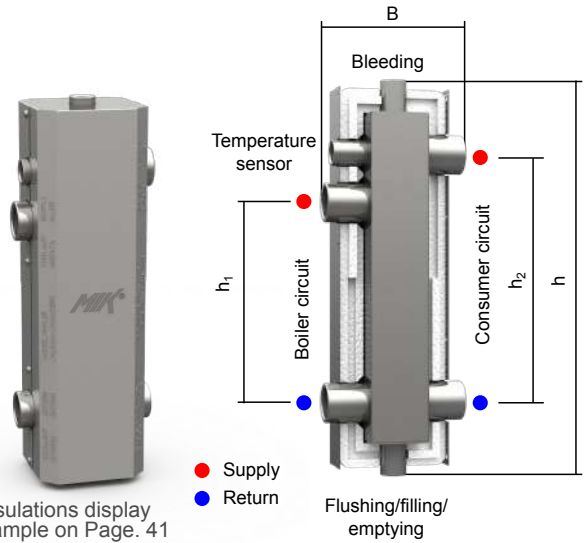

\*Insulations display example on Page. 41

Type	Built-in height h [mm]	Built-in width B [mm]	Boiler connections distance h <sub>1</sub> [mm]	Consumer connections distance h <sub>2</sub> [mm]	Code -heating*	Code -cooling*
HW 60/250	397	142	200	250	<b>850 009</b>	<b>850 009 1</b>

## Hydraulic separator HW 60

Flow rates up to 3 m<sup>3</sup>/h

- Material: S235 carbon steel
- Zinc flake coated chamber flZn-nc-480h acc. DIN EN ISO 10683
- Insulation for heating or cooling with 0,6 mm galvanised sheet steel jacket
- Supply/return and boiler/consumer markings stamped into sheet steel jacket

### Technical specification

Boiler connections	internal thread G 1"
Consumer connections	internal thread G 1"
Insulation <sub>Heating</sub>	EPS 25 mm (EN 13501-1 E)
Insulation <sub>Cooling</sub>	FEF 19 mm (EN 13501-1 B,s3,d0)
Max. working temperature <sub>EPS</sub>	90 °C
Max. working temperature <sub>FEF</sub>	85 °C
Max. working pressure	6 bar
Volume	1,4 l

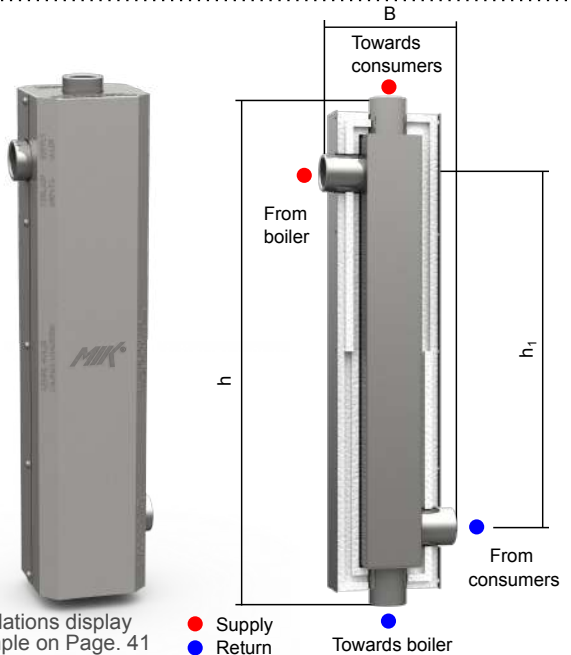

\*Insulations display example on Page. 41

Type	Built-in height h [mm]	Built-in width B [mm]	Connections distance h <sub>1</sub> [mm]	Code -heating*	Code -cooling*
HW 60	536	142	375	<b>850 005</b>	<b>850 005 1</b>

## MIK Wall brackets H-HV

- 100 or 150 mm distance from separator centre to wall
- Galvanized (HRN EN ISO 2081) and chromated (DIN 50962)
- The kit includes screws and dowels
- Pack contents 2 pcs.
- Code: **840 007** (100 mm)
- **840 008** (150 mm)



## Heating circuit modules HK 25

For power up to 50 kW at a temperature difference of 20 °C and flow rate of 2,15 m<sup>3</sup>/h

- Connections distance, D = 125 mm
- Built-in height, H = 380 mm
- Built-in width, B = 250 mm
- K<sub>vs</sub> value: 8,0
- Standard version: right supply
- Possible installation with left supply according to the product instructions



## Heating circuit module HK 25-2 with insulation, unmixed

### Return

Internal thread G 1" connection

Flanged ball valve supplied with in-handle thermometer

- Connection to pipe: oval flange
- Supplied with non return valve:



- Non return valve can be switched off by turning the hand dial by 45°

Connection pipe

- Length: 265 mm
- Connections: external thread G 1 ½"

Screw coupling 1"

- Set: G 1 ½" nut, adapter internal thread G 1", gasket



### Supply

Internal thread G 1" connection

Flanged ball valve supplied with in-handle thermometer

- Connection to pump: oval flange

Pump

- Port to port length: 180 mm
- Connections: external thread G 1 ½"

Union nut 1 ½"

- Set: G 1 ½" nut, gasket

Flanged ball valve with T-handle

- Bottom connection: external thread G 1 ½"
- Connection to pump: oval flange

Specification	Type	Code
only pump set armature with insulation, without pump	HK 25-2	<b>870 002</b>
possible to order a pump in addition to armature	Grundfos UPM3 Hybrid 25-70 (UL7)	<b>870 103</b>

## Heating circuit module HK 25-2B with insulation and overflow valve, unmixed

Overflow valve

- Variant with overflow valve



Specification	Type	Code
only pump set armature with insulation, without pump	HK 25-2B	<b>870 012</b>
possible to order a pump in addition to armature	Grundfos UPM3 Hybrid 25-70 (UL7)	<b>870 103</b>

## Heating circuit modules HK 25

For power up to 35 kW at a temperature difference of 20 °C and flow rate of 1,5 m<sup>3</sup>/h

- Connections distance, D = 125 mm
- Built-in height, H = 380 mm
- Built-in width, B = 250 mm
- K<sub>vs</sub> value: 6,0
- Standard version: right supply
- Possible installation with left supply according to the product instructions



## Heating circuit module HK 25-3 with 3-way mixing valve and insulation

### Return

Internal thread G 1" connection

Flanged ball valve supplied with in-handle thermometer

- Connection to pipe: oval flange
- Supplied with non return valve:

- Non return valve can be switched off by turning the hand dial by 45°

Connection pipe

- Length: 180 mm
- Connections: external thread G 1 1/2"

Union nut 1 1/2"

- Set: G 1 1/2" nut, gasket

T piece

- Bottom connection: external thread G 1 1/2"
- Connection to brass pipe: oval flange

Screw coupling 1"

- Set: G 1 1/2" nut, adapter internal thread G 1", gasket

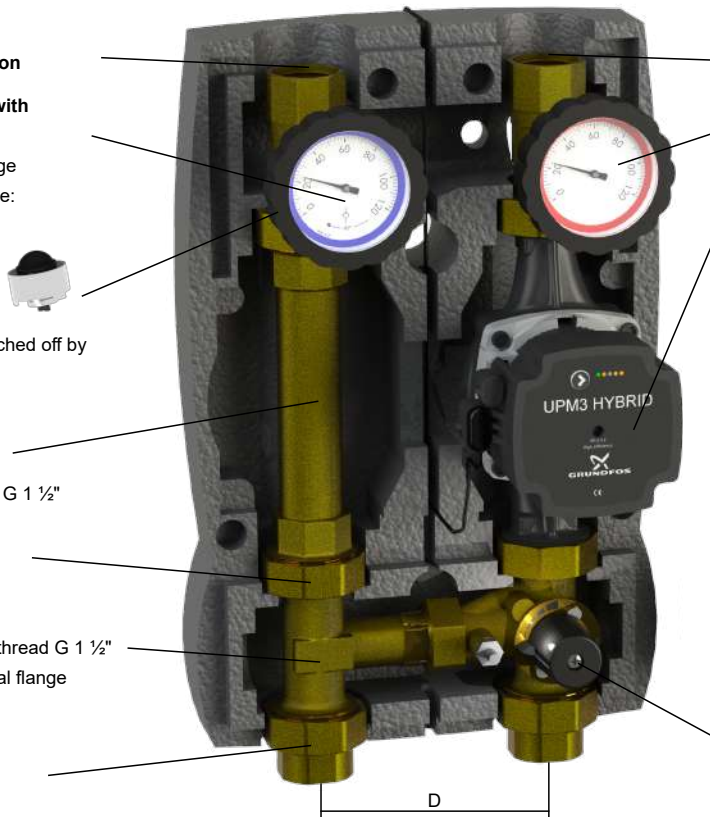

### Supply

Internal thread G 1" connection

Flanged ball valve supplied with in-handle thermometer

- Connection to pump: oval flange

Pump

- Port to port length: 180 mm
- Connections: external thread G 1 1/2"

Servomotor MODVLVS M21

- 3 points servomotor for mixing valve
- LED operation indication
- Running speed: 2 min to 90°
- Torque: 5 Nm
- Power supply: 230 V
- Additionally, circuit module can be combined with SELTRON and ESBE servomotors



3-way mixing valve

- Bottom connection: external thread G 1 1/2"
- Connection to pump: oval flange

Specification	Type	Code
only pump set armature with insulation, without pump or servomotor	HK 25-3	<b>870 003</b>
possible to order a pump in addition to armature	Grundfos UPM3 Hybrid 25-70 (UL7)	<b>870 103</b>
possible to order a servomotor in addition to armature	Servomotor MODVLVS M21	<b>870 050</b>

## Heating circuit module HK 25-3B with 3-way mixing, overflow valve and insulation

Overflow valve

- Variant with overflow valve

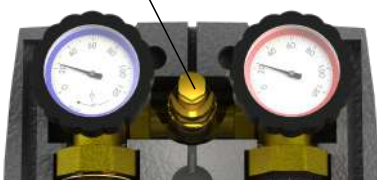

Specification	Type	Code
only pump set armature with insulation, without pump or servomotor	HK 25-3B	<b>870 013</b>
possible to order a pump in addition to armature	Grundfos UPM3 Hybrid 25-70 (UL7)	<b>870 103</b>
possible to order a servomotor in addition to armature	Servomotor MODVLVS M21	<b>870 050</b>



## Boiler safety unit with insulation SG/I 50

- Mounting assembly for self-contained heating systems up to 50 kW
- Ready for use - equipped with: manometer with automatic shut-off valve, quick air bleeding system with automatic shut-off valve and safety valve 3 bar
- EPS insulation 20 mm (EN 13501-1 E)
- Boiler connection: internal thread G 1"

Code

860 050



## Steel chamber K2a for boiler safety unit SG/I 50

- Mounting assembly for self-contained heating systems up to 50 kW
- Manometer and bleeding valve connections: internal thread G 3/8"
- Safety valve connection: external thread R 1/2"
- Boiler connection: internal thread G 1"

860 212



## Boiler safety unit with insulation SG/I 50 DD

- Mounting assembly for self-contained heating systems up to 50 kW
- Ready for use - equipped with: manometer with automatic shut-off valve, quick air bleeding system with automatic shut-off valve and safety valve 3 bar
- EPS insulation 20 mm (EN 13501-1 E)
- Boiler connection: external thread R 1"

860 050 DD



## Steel chamber K2a DD for boiler safety unit SG/I 50 DD

- Mounting assembly for self-contained heating systems up to 50 kW
- Manometer and bleeding valve connections: internal thread G 3/8"
- Safety valve connection: external thread R 1/2"
- Boiler connection: external thread R 1"

860 312



## EPS insulation for safety units (K2a-K5a)

- EPS insulation 20 mm (EN 13501-1 E) for MIK boiler safety units

IZOLEPS-SG

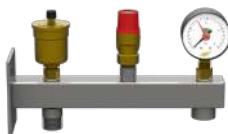

## Multi-function unit for expansion tank UWK 1

- Mounting assembly for self-contained heating systems
- Ready for use - equipped with: manometer with automatic shut-off valve, quick air bleeding system with automatic shut-off valve and safety valve 3 bar
- Boiler connection: external thread R 3/4"
- Expansion tank connection: internal connection G 3/4"

860 122

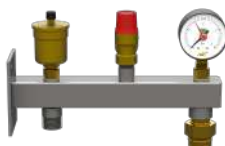

## Multi-function unit for expansion tank UWK 1 SK

- Mounting assembly for self-contained heating systems
- Ready for use - equipped with: manometer with automatic shut-off valve, quick air bleeding system with automatic shut-off valve, safety valve 3 bar and quick-disconnect coupling 3/4 for expansion tank connection
- Boiler connection: external thread R 3/4"
- Expansion tank connection: internal connection G 3/4"

860 124

## Steel chamber console for UWK 1

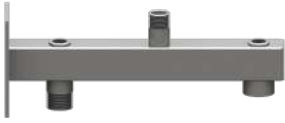

- Application in self-contained heating systems
- Manometer and bleeding valve connections: internal thread G 3/8"
- Safety valve connection: external thread R 1/2"
- Boiler connection: external thread R 3/4"
- Expansion tank connection: internal connection G 3/4"

Code

860 103

## Steel chamber console for UWK 2



- Application in self-contained heating systems
- Boiler connection: external thread R 3/4"
- Manometer and bleeding valve connections: internal thread G 3/8"
- Safety valve connection: internal thread G 1/2"
- Expansion tank connection: internal thread G 3/4"

860 104

## Stainless steel multi-function unit for expansion tanks EWK 2

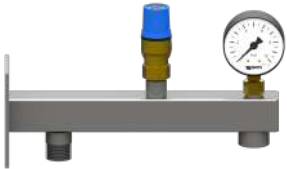

- Mounting assembly for sanitary systems
- Sanitary system connection: external thread R 3/4"
- Expansion tank connection: internal thread G 3/4"
- Ready for use - equipped with: manometer with automatic shut-off valve and safety valve 10 bar

860 135

## Stainless steel chamber console for EWK 2



- Application in sanitary systems
- Sanitary system connection: external thread R 3/4"
- Expansion tank connection: internal thread G 3/4"
- Safety valve connection: external thread R 1/2"
- Manometer connection: internal thread G 1/4"

860 115

## Stainless steel chamber console for EWK 1



- Application in sanitary systems
- Sanitary system connection: external thread R 3/4"
- Expansion tank connection: internal thread G 3/4"
- Safety valve connection: external thread R 1/2"
- Manometer connection: internal thread G 3/8"

860 114

## Manometer $\varnothing 63/3/8$ "/4 bar



- Application in sanitary and heating systems
- Pressure gauge with connected connection adapter G 3/8"
- Pressure range: 0 - 4 bar
- Note: adapter thread need to be sealed

MANOM63-3/8-4B

## Shut-off valve for manometer $3/8$ "



- Adapter with shut-off valve for manometer 3/8"

REM 8-3/8

## Manometer $\varnothing 63/1/4$ "/10 bar



- Application in sanitary and solar systems
- Pressure range: 0 - 10 bar
- Connection: external thread G 1/4"

MANOM63-1/4-10B

## Shut-off valve for manometer $1/4$ "



- Adapter with shut-off valve for manometer 1/4"

REM 8-1/4





## Automatic air vent valve Minivent MV10.R 3/8" 12 bar

- Automatic venting of closed heating systems
- Connection: external thread G 3/8"
- Equipped with adapter G 3/8" with automatic shut-off valve

Code

**MINIVENT MV10R**



## Quick-disconnect coupling SK 3/4"

- Quick-disconnect coupling for connecting the expansion tank
- Set:
  - Union nut G 1"
  - External thread G 3/4" fitting with automatic shut-off valve
  - Adapter with automatic shut-off valve external thread G 1"/ internal thread G 3/4"

**BRZA SPOJNICA SK3/4**



## Safety valve SVH/E 1/2" 3 bar

- For heating systems with output up to 50 kW
- Maximum pressure: 3 bar
- Inlet connection: internal thread G 1/2"
- Outlet connection: internal thread G 3/4"

**SVH/E 1/2-3B**



## Safety valve SVW 1/2" 10 bar

- For sanitary system with rated power up to 75 kW and flow rate up to 200 liters
- Maximum pressure: 10 bar
- Inlet connection: internal thread G 1/2"
- Outlet connection: internal thread G 3/4"

**SVW 1/2-10B**



## Screw coupling 1"

- Set:
  - G 1 1/2" nut
  - Adapter internal thread G 1"
  - Gasket
  - Adapter external thread G 1 1/2"/internal thread G 1"

**HOL-1"**



## Union nut 1 1/2" with gasket

- Set:
  - G 1 1/2" nut
  - Gasket

**870 000.14**



## Servomotor MODVLVS M21

- 3 points servomotor for mixing valves
- LED operation indication
- Running speed: 2 min to 90°
- Torque: 5 Nm
- Power supply: 230 V

**870 050**



## Circulating pump Grundfos UPM3 HYBRID 25-70-180

- Port to port length: 180 mm
- Connections: external thread G 1 1/2"

**870 103**

- HV 70/125-4 MIK boiler manifold (840 104)
- HW 60/375 MIK hydraulic separator (850 013)
- HK 25-2 Heating circuit module (870 002)
- HK 25-3 Heating circuit module (870 003)
- HK 32-3 Heating circuit module (871 003)
- UWK 1 SK MIK Multi-function unit for expansion tank with quick-disconnect coupling (860 124)
- UWK S MIK Multi-function unit for expansion tank for solar systems (860 125)
- EWK 2 MIK Stainless steel multi-function unit for expansion tank (860 135)
- SG/I 100 MIK Boiler safety unit (860 100)
- HOP2.5 MIK Horizontal air vent vessel (830 001)
- Adapter for HK 32 (870 061)
- Air vent valve 3/8" (MINIVENT MV10R)
- H-HV 100 MIK Wall bracket (840 007)
- LU-HV 100-150 MIK Wall bracket (840 012)
- 1 Solid fuel firing boiler
- 2 Drain valve
- 3 Temperature sensor
- 4 Regulation
- 5 Radiator
- 6 Underfloor heating
- 7 Solar collector
- 8 Pump unit for solar system
- 9 Room thermostat
- 10 Use of sanitary water
- 11 Sanitary water tank
- 12 Expansion tank
- 13 Water supply

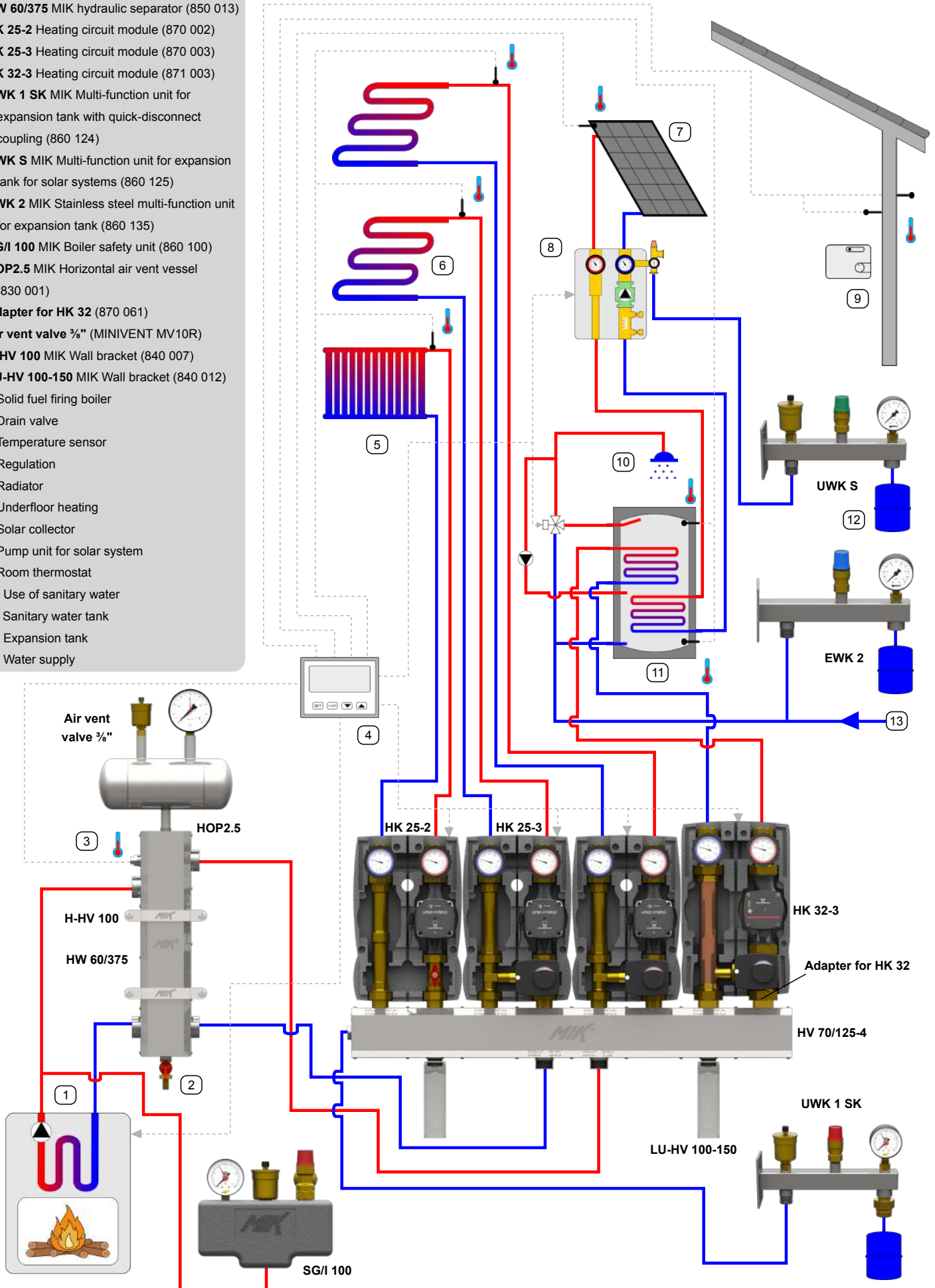

## Combined supply-return manifold HV 70/125

Up to 75 kW output at the temperature difference of 20 °C and flow rate of 3,3 m<sup>3</sup>/h

- 2 to 7 heating/cooling circuits
- Boiler connections underneath
- Consumer connections above
- Supply and return connections located side by side
- Compact construction with integrated supply and return
- Material: S235 carbon steel
- Zinc flake coated chambers flZn-nc-480h acc. DIN EN ISO 10683
- Insulation for heating or cooling with 0,6 mm galvanised sheet steel jacket
- Supply and return markings stamped into sheet steel jacket
- Expansion tank/drain valve connection

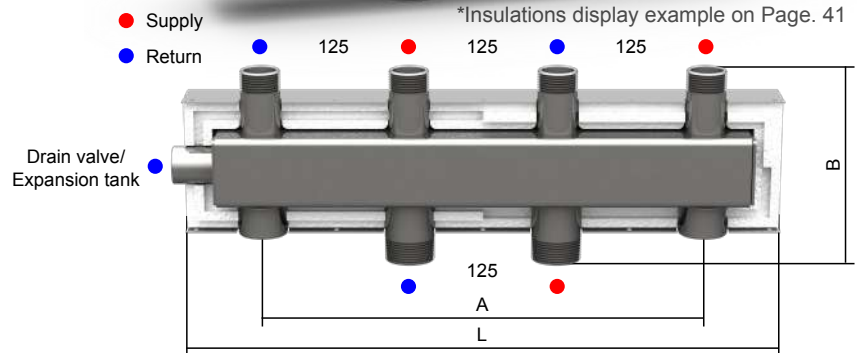

### Technical specification

Boiler connections	external thread R 1 ¼"
Consumer connections	external thread R 1"
Expansion tank/drain valve	internal thread G ¾"
Insulation <sub>Heating</sub>	EPS 25 mm (EN 13501-1 E)
Insulation <sub>Cooling</sub>	FEF 19 mm (EN 13501-1 B,s3,d0)
Max. working temperature <sub>EPS</sub>	90 °C
Max. working temperature <sub>FEF</sub>	85 °C
Max. working pressure	6 bar
K <sub>vs</sub> value	30,6
Connections distance	125 mm
Installation height, B	165 mm
Insulation height	115 mm
Produced acc.	2014/68/EU

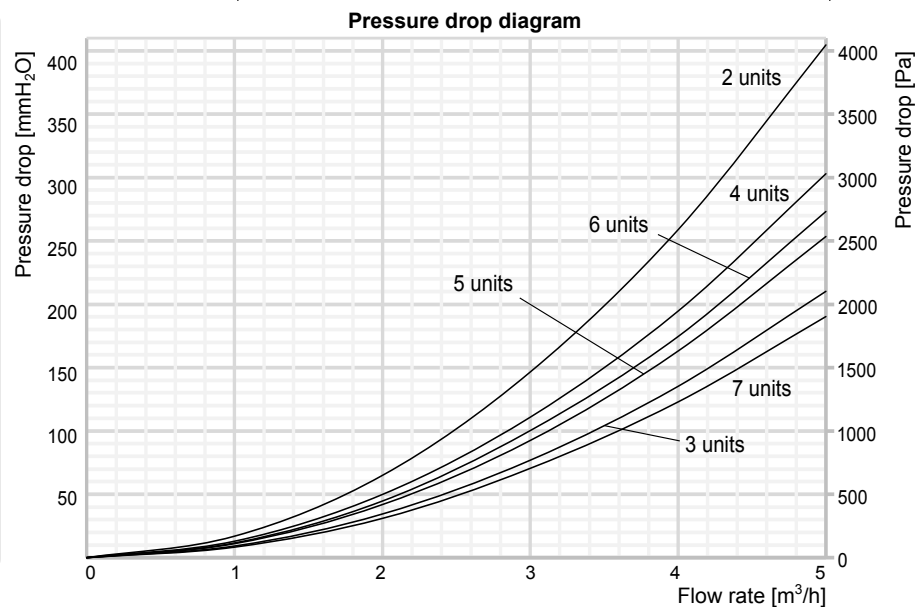

Type	Built-in length L [mm]	Offset of supports A [mm]	Consumer units	Code -heating*	Code -cooling*
HV 70/125-2	506	375	2	840 102	840 102 1
HV 70/125-3	756	375	3	840 103	840 103 1
HV 70/125-4	1006	625	4	840 104	840 104 1
HV 70/125-5	1256	625	5	840 105	840 105 1
HV 70/125-6	1506	875	6	840 106	840 106 1
HV 70/125-7	1756	875	7	840 107	840 107 1

### MIK Wall bracket LU-HV 100-150

- 100 or 150 mm distance from manifold centre to wall
- Galvanized (HRN EN ISO 2081) and chromated (DIN 50962)
- The kit includes screws, dowels, washers and damping elements
- Pack contents 2 pcs.
- Code: **840 012**



## Hydraulic separator HWK 60-1 ¼"

Flow rates up to 4 m<sup>3</sup>/h

- Material: S235 carbon steel
- Zinc flake coated chamber flZn-nc-480h acc. DIN EN ISO 10683
- Insulation for heating or cooling with 0,6 mm galvanised sheet steel jacket
- Supply/return and boiler/consumer markings stamped into sheet steel jacket
- Bleeding and flushing/filling/emptying connections

### Technical specification

Boiler connections	internal thread G 1 ¼"
Consumer connections	internal thread G 1 ¼"
InsulationHeating	EPS 25 mm (EN 13501-1 E)
InsulationCooling	FEF 19 mm (EN 13501-1 B,s3,d0)
Max. working temperature <sub>EPS</sub>	90 °C
Max. working temperature <sub>FEF</sub>	85 °C
Max. working pressure	6 bar
Volume	1,4 l
Bleeding	internal thread G ½"
Flushing/filling/emptying	internal thread G ½"

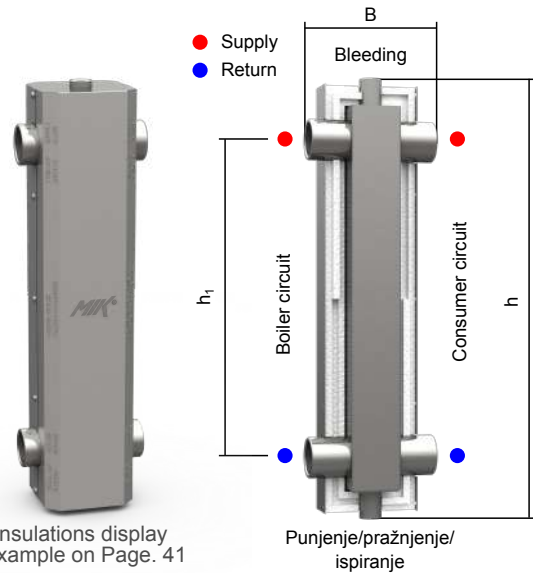

\*Insulations display example on Page. 41

Type	Built-in height h [mm]	Built-in width B [mm]	Distance of boiler and consumer connections h <sub>1</sub> [mm]	Code -heating* -cooling*
HWK 60-1 ¼"	522	152	375	<b>850 008</b> <b>850 008 1</b>

## Hydraulic separator HW 60/125-1 ¼"

Flow rates up to 3 m<sup>3</sup>/h

- Material: S235 carbon steel
- Zinc flake coated chamber flZn-nc-480h acc. DIN EN ISO 10683
- Insulation for heating or cooling with 0,6 mm galvanised sheet steel jacket
- Supply/return and boiler/consumer markings stamped into sheet steel jacket
- Temperature sensor connection
- Equipped with two 1 ¼" union flat seat fittings



### Technical specification

Boiler connections	internal thread G 1 ¼"
Consumer connections	external thread R 1 ¼"
InsulationHeating	EPS 25 mm (EN 13501-1 E)
InsulationCooling	FEF 19 mm (EN 13501-1 B,s3,d0)
Max. working temperature <sub>EPS</sub>	90 °C
Max. working temperature <sub>FEF</sub>	85 °C
Max. working pressure	6 bar
Volume	1,0 l
Temperature sensor	internal thread G ½"
Pressure drop at max. recirculation	< 1200 Pa



\*Insulations display example on Page. 41

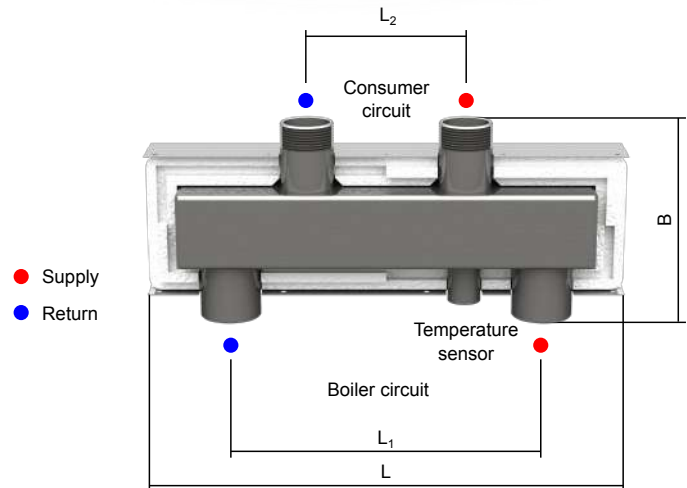

Type	Built-in length L [mm]	Built-in height B [mm]	Boiler connections distance L <sub>1</sub> [mm]	Consumer connections distance L <sub>2</sub> [mm]	Code -heating*	Code -cooling*
HW 60/125-1 ¼"	381	158,5	250	125	<b>850 011</b>	<b>850 011 1</b>

## MIK Wall brackets H-HV

- 100 or 150 mm distance from separator centre to wall
- Galvanized (HRN EN ISO 2081) and chromated (DIN 50962)
- The kit includes screws and dowels
- Pack contents 2 pcs.
- Code: **840 007** (100 mm)  
**840 008** (150 mm)



## Hydraulic separator HW 60/375

Flow rates up to 4 m<sup>3</sup>/h

- Material: S235 carbon steel
- Zinc flake coated chamber flZn-nc-480h acc. DIN EN ISO 10683
- Insulation for heating or cooling with 0,6 mm galvanised sheet steel jacket
- Supply/return and boiler/consumer markings stamped into sheet steel jacket
- Bleeding and flushing/filling/emptying connections
- Temperature sensor connection

### Technical specification

Boiler connections	internal thread G 1 1/4"
Consumer connections	internal thread G 1 1/4"
Insulation <sub>Heating</sub>	EPS 25 mm (EN 13501-1 E)
Insulation <sub>Cooling</sub>	FEF 19 mm (EN 13501-1 B,s3,d0)
Max. working temperature <sub>EPS</sub>	90 °C
Max. working temperature <sub>FEF</sub>	85 °C
Max. working pressure	6 bar
Volume	1,4 l
Bleeding	internal thread G 1/2"
Temperature sensor	internal thread G 1/2"
Flushing/filling/emptying	internal thread G 1/2"
Pressure drop at max. recirculation	< 800 Pa

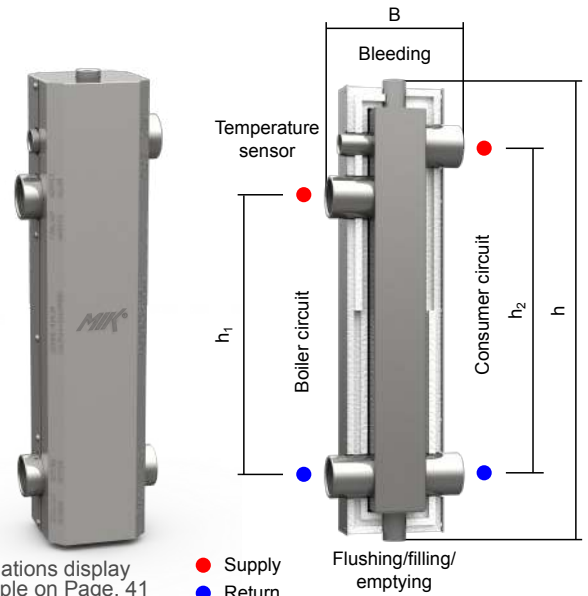

Type	Built-in height h [mm]	Built-in width B [mm]	Boiler connections distance h <sub>1</sub> [mm]	Consumer connections distance h <sub>2</sub> [mm]	Code -heating* -cooling*
HW 60/375	522	152	315	375	<b>850 013</b> <b>850 013 1</b>

## Hydraulic separator HW 60/375A

Flow rates up to 4 m<sup>3</sup>/h

- Material: S235 carbon steel
- Zinc flake coated chamber flZn-nc-480h acc. DIN EN ISO 10683
- Insulation for heating or cooling with 0,6 mm galvanised sheet steel jacket
- Supply/return and boiler/consumer markings stamped into sheet steel jacket
- Flushing/filling/emptying connection
- Temperature sensor connection
- Boiler safety unit connection

### Technical specification

Boiler connections	internal thread G 1 1/4"
Consumer connections	internal thread G 1 1/4"
Insulation <sub>Heating</sub>	EPS 25 mm (EN 13501-1 E)
Insulation <sub>Cooling</sub>	FEF 19 mm (EN 13501-1 B,s3,d0)
Max. working temperature <sub>EPS</sub>	90 °C
Max. working temperature <sub>FEF</sub>	85 °C
Max. working pressure	6 bar
Volume	1,4 l
Flushing/filling/emptying	internal thread G 1/2"
Temperature sensor	internal thread G 1/2"
Boiler safety unit	external thread R 1"
Pressure drop at max. recirculation	< 800 Pa

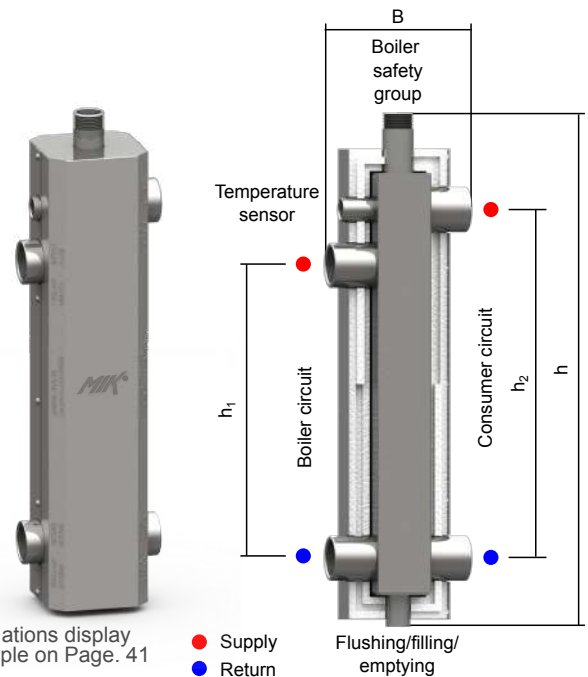

Type	Built-in height h [mm]	Built-in width B [mm]	Boiler connections distance h <sub>1</sub> [mm]	Consumer connections distance h <sub>2</sub> [mm]	Code -heating* -cooling*
HW 60/375A	522	152	315	375	<b>850 013 A</b> <b>850 013 1A</b>

## MIK Wall brackets H-HV

- 100 or 150 mm distance from separator centre to wall
- Galvanized (HRN EN ISO 2081) and chromated (DIN 50962)
- The kit includes screws and dowels
- Pack contents 2 pcs.
- Code: **840 007** (100 mm)
- **840 008** (150 mm)



### Heating circuit module HK 32-2 with insulation

For power up to 111 kW at a temperature difference of 20 °C and flow rate of 4,8 m<sup>3</sup>/h

- Connections distance, D = 125 mm
- Built-in height, H = 400 mm
- Built-in width, B = 250 mm
- K<sub>vs</sub> value: 21,0
- Standard version: right supply
- Possible installation with left supply according to the product instructions



#### Return

Internal thread G 1 ¼" connection

Flanged ball valve supplied with in-handle thermometer

- Connection to pipe: oval flange

Non return valve



Connection pipe

- Length: 285 mm
- Connections: external thread G 2"

Screw coupling 1 ¼"

- Set: G 2" nut, adapter internal thread G 1 ¼", gasket

#### Supply

Internal thread G 1 ¼" connection

Flanged ball valve supplied with in-handle thermometer

- Connection to pump: oval flange

Pump

- Port to port length: 180 mm
- Connections: external thread G 2"

Union nut 2"

- Set: G 2" nut, gasket

Flanged ball valve with T-handle

- Bottom connection: external thread G 2"
- Connection to pump: oval flange

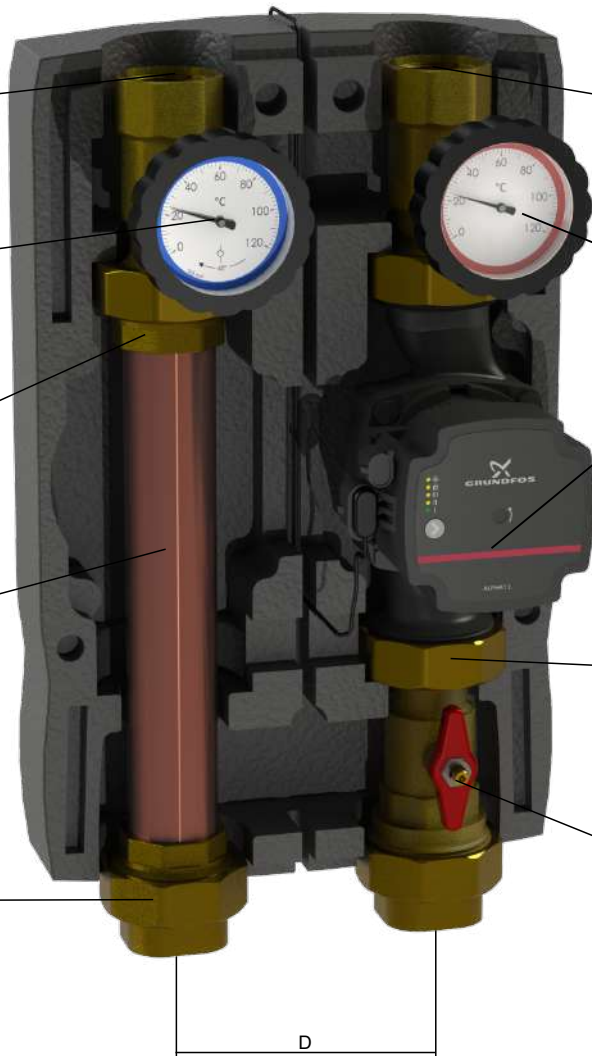

Specification

Type

Code

only pump set armature with insulation, without pump

HK 32-2

871 002

### Heating circuit module HK 32-3 with 3-way mixing valve and insulation

For power up to 93 kW at a temperature difference of 20 °C and flow rate of 4,0 m<sup>3</sup>/h

- Connections distance, D = 125 mm
- Built-in height, H = 400 mm
- Built-in width, B = 250 mm
- K<sub>vs</sub> value: 13,0
- Standard version: right supply
- Possible installation with left supply according to the product instructions



#### Return

**Internal thread**  
G 1 ¼" connection

**Flanged ball valve supplied with in-handle thermometer**  
□ Connection to pipe: oval flange

**Union nut 2"**  
□ Set: G 2" nut, gasket

**Non return valve**



**Connection pipe**  
□ Length: 285 mm  
□ Connections: external thread G 2"

**Screw coupling 1 ¼"**  
□ Set: G 2" nut, adapter internal thread G 1 ¼", gasket

#### Supply

**Internal thread**  
G 1 ¼" connection

**Flanged ball valve supplied with in-handle thermometer**  
□ Connection to pump: oval flange

#### Pump

- Port to port length: 180 mm
- Connections: external thread G 2"

#### Servomotor MODVLVS M21

- 3 points servomotor for mixing valve
- LED operation indication
- Running speed: 2 min to 90°
- Torque: 5 Nm
- Power supply: 230 V
- Additionally, circuit module can be combined with SELTRON and ESBE servomotors



#### 3-way mixing valve

- Bottom connection: external thread G 2"
- Connection to pump: oval flange

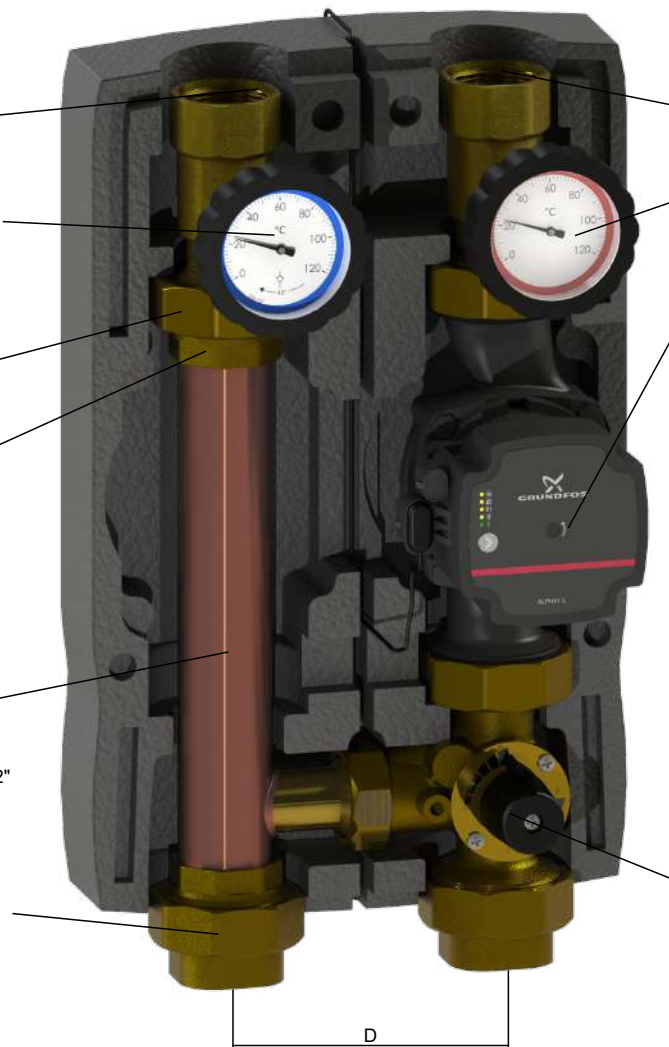

Specification	Type	Code
only pump set armature with insulation, without pump or servomotor	HK 32-3	871 003
possible to order a servomotor in addition to armature	Servomotor MODVLVS M21	870 050



## Boiler safety unit with insulation SG/I 100

- Mounting assembly for self-contained heating systems up to 100 kW
- Ready for use - equipped with: manometer with automatic shut-off valve, quick air bleeding system with automatic shut-off valve and safety valve 3 bar
- EPS insulation 20 mm (EN 13501-1 E)
- Boiler connection: internal thread G 1"

Code

860 100



## Steel chamber K3a for boiler safety unit SG/I 100

- Mounting assembly for self-contained heating systems up to 100 kW
- Manometer and bleeding valve connections: internal thread G 3/8"
- Safety valve connection: external thread R 1/4"
- Boiler connection: internal thread G 1"

860 213



## Boiler safety unit with insulation SG/I 100 DD

- Mounting assembly for self-contained heating systems up to 100 kW
- Ready for use - equipped with: manometer with automatic shut-off valve, quick air bleeding system with automatic shut-off valve and safety valve 3 bar
- EPS insulation 20 mm (EN 13501-1 E)
- Boiler connection: external thread R 1"

860 100 DD



## Steel chamber K3a DD for boiler safety unit SG/I 100 DD

- Mounting assembly for self-contained heating systems up to 100 kW
- Manometer and bleeding valve connections: internal thread G 3/8"
- Safety valve connection: external thread R 1/4"
- Boiler connection: external thread R 1"

860 313



## EPS insulation for safety units (K2a-K5a)

- EPS insulation 20 mm (EN 13501-1 E) for MIK boiler safety units

IZOLEPS-SG

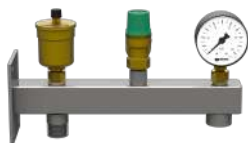

## Multi-function unit for expansion tank UWK S for solar systems

- Mounting assembly for solar systems
- Ready for use - equipped with: manometer with automatic shut-off valve, quick air bleeding system with automatic shut-off valve and safety valve 6 bar
- Boiler connection: external thread R 1/4"
- Expansion tank connection: internal connection G 3/4"

860 125









## Steel chamber console for UWK S

- Application in solar systems
- Boiler connection: external thread R 1/4"
- Bleeding connection: internal thread G 3/8"
- Manometer connection: internal thread G 1/4"
- Safety valve connection: external thread R 1/2"
- Expansion tank connection: internal thread G 3/4"

860 106

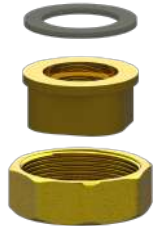

		Code
	<p><b>Safety valve SVH/E 3/4" 3 bar</b></p> <ul style="list-style-type: none"> <li><input type="checkbox"/> For heating systems with output up to 100 kW</li> <li><input type="checkbox"/> Maximum pressure: 3 bar</li> <li><input type="checkbox"/> Inlet connection: internal thread G 3/4"</li> <li><input type="checkbox"/> Outlet connection: internal thread G 1"</li> </ul>	<b>SVH/E 3/4-3B</b>
	<p><b>Safety valve SVE/SOL 1/2" 6 bar</b></p> <ul style="list-style-type: none"> <li><input type="checkbox"/> For solar heating systems with up to 50 kW output and solar panel surface up to 50 m<sup>2</sup></li> <li><input type="checkbox"/> Maximum pressure: 6 bar</li> <li><input type="checkbox"/> Inlet connection: internal thread G 1/2"</li> <li><input type="checkbox"/> Outlet connection: internal thread G 3/4"</li> </ul>	<b>SVE/SOL 1/2-6B</b>
	<p><b>Screw coupling 1 1/4"</b></p> <ul style="list-style-type: none"> <li><input type="checkbox"/> Set: <ul style="list-style-type: none"> <li><input type="checkbox"/> G 2" nut</li> <li><input type="checkbox"/> Internal thread G 1 1/4" connection</li> <li><input type="checkbox"/> Gasket</li> <li><input type="checkbox"/> Adapter external thread G 2"/internal thread G 1 1/4"</li> </ul> </li> </ul>	<b>HOL-5/4"</b>
	<p><b>Union nut 2" with gasket</b></p> <ul style="list-style-type: none"> <li><input type="checkbox"/> Set: <ul style="list-style-type: none"> <li><input type="checkbox"/> G 2" nut</li> <li><input type="checkbox"/> Gasket</li> </ul> </li> </ul>	<b>871 000.14</b>
	<p><b>Adapter for DN32 pump units</b></p> <ul style="list-style-type: none"> <li><input type="checkbox"/> Adapter DN25 to DN32 for connecting HK 32 pump units</li> <li><input type="checkbox"/> Set: <ul style="list-style-type: none"> <li><input type="checkbox"/> Gasket</li> <li><input type="checkbox"/> Internal thread G 1" connection</li> <li><input type="checkbox"/> Union nut G 2"</li> </ul> </li> </ul>	<b>870 061</b>
	<p><b>Horizontal air vent vessel HOP2.5</b></p> <ul style="list-style-type: none"> <li><input type="checkbox"/> Volume 2,5 liters</li> <li><input type="checkbox"/> Automatic venting of closed heating systems</li> <li><input type="checkbox"/> Galvanized (HRN EN ISO 2081) and chromated (DIN 50962)</li> <li><input type="checkbox"/> Main connection: external thread R 1/2"</li> <li><input type="checkbox"/> Manometer connection: internal thread G 1/2"</li> <li><input type="checkbox"/> Bleeding connection: internal thread G 3/8"</li> </ul>	<b>830 001</b>

## Left mounting

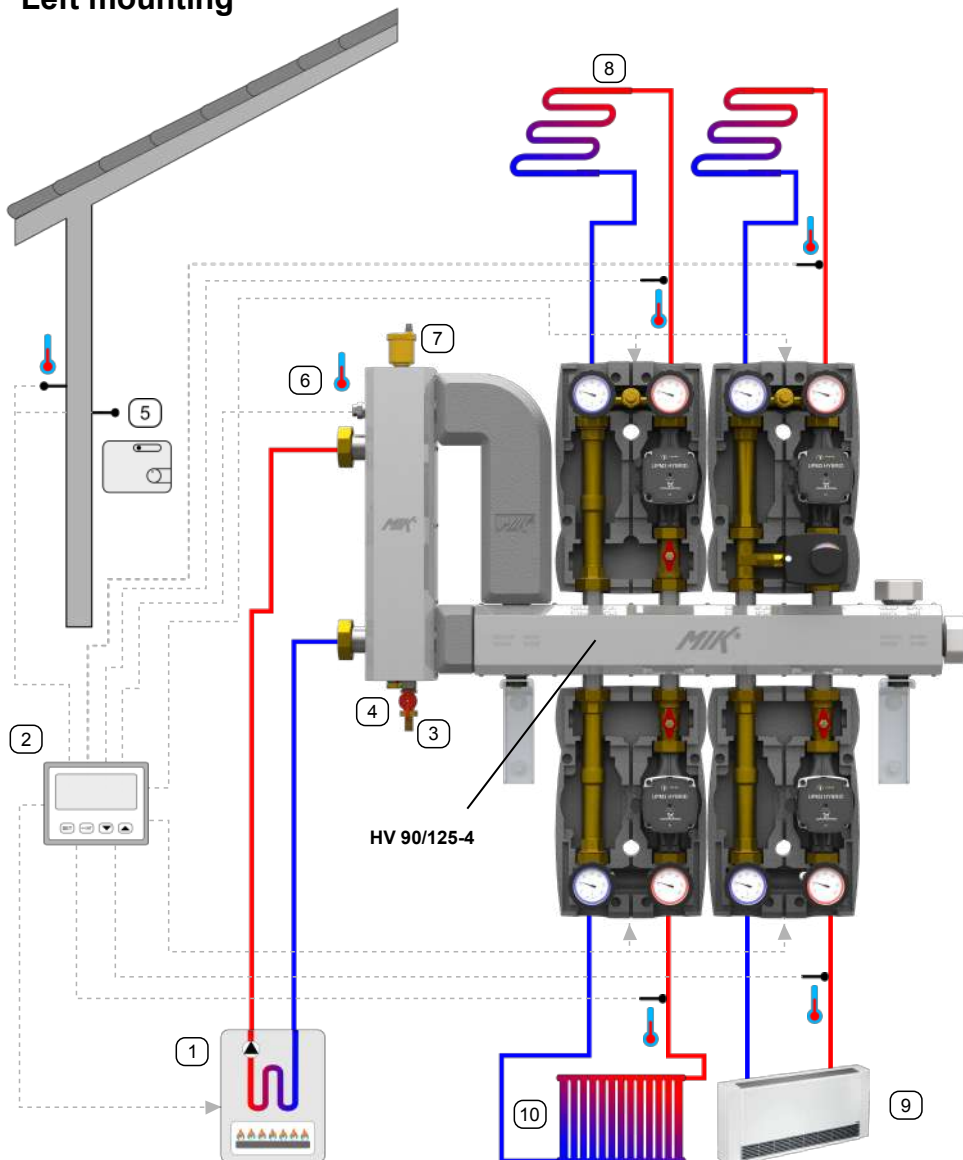

- HV 90/125-4** MIK boiler manifold (840 204)
- HV 90/125-6** MIK boiler manifold (840 206)
- HW 60/375 OF** MIK hydraulic separator (850 015)
- HK 25-2** Pump unit/Heating circuit module (870 002)
- HK 25-3** Pump unit/Heating circuit module (870 003)
- HK 25-3B** Pump unit/Heating circuit module (870 013)
- LU-HV 100-150** MIK Wall bracket (840 012)
- Union nut G 1 1/2"** (870 000.14)
- Screw plug G 1 1/2"** (870 000.16)
- Union nut G 2"** (871 000.14)
- Blank nut cap G 2"** (KAPA-2")
- VR 32** Connection tube (600 086)
- 1** Gas boiler
- 2** Regulation
- 3** Drain valve
- 4** Magnetic dirt separator
- 5** Room thermostat
- 6** Temperature sensor
- 7** Bleeding valve
- 8** Underfloor heating
- 9** Fan coil
- 10** Radiator

## Right mounting

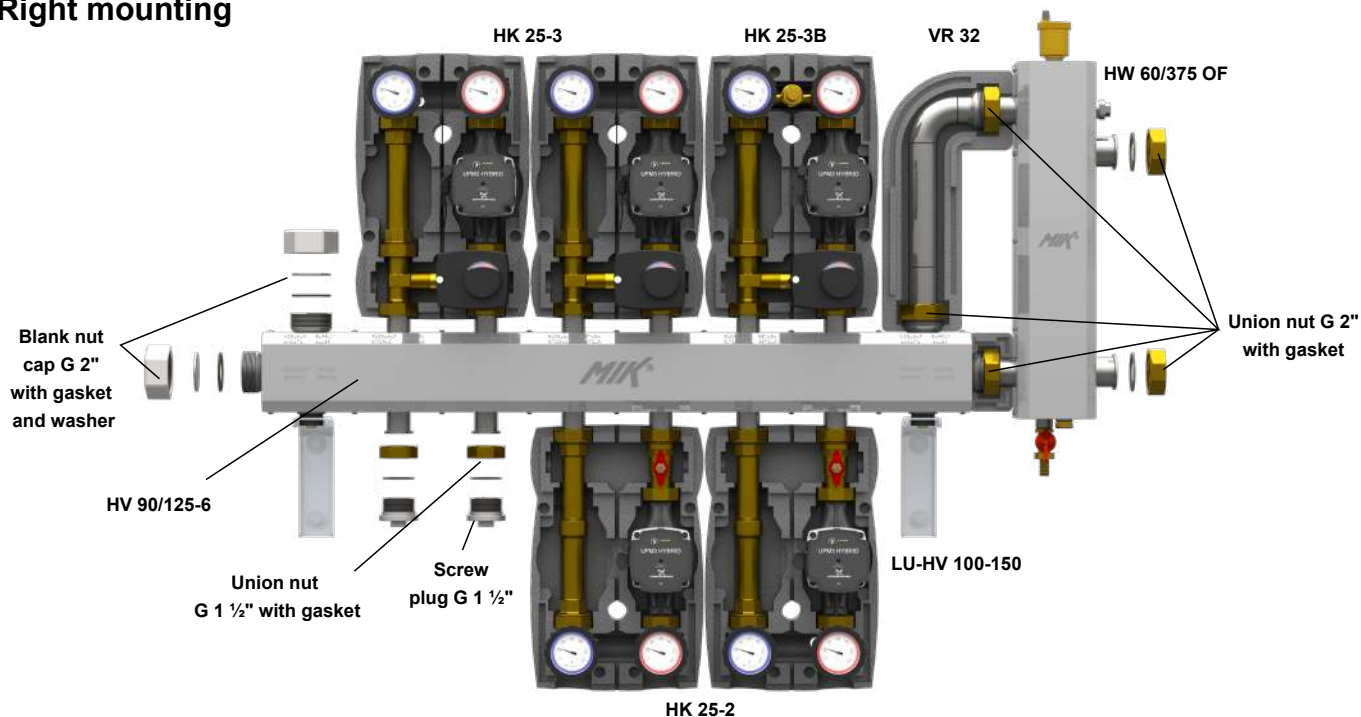

## Combined supply-return manifold DN32, HV 90/125

Up to 90 kW output at a temperature difference of 20 °C and flow rate of 4 m<sup>3</sup>/h

- 2 to 6 heating/cooling circuits
- Left and right boiler connections
- Upper and lower consumer connections
- Supply and return connections located side by side
- Compact construction with integrated supply and return
- Material: S235 carbon steel
- Zinc flake coated chambers flZn-nc-480h acc. DIN EN ISO 10683
- Insulation for heating or cooling with 0,6 mm galvanised sheet steel jacket
- Supply and return markings stamped into sheet steel jacket

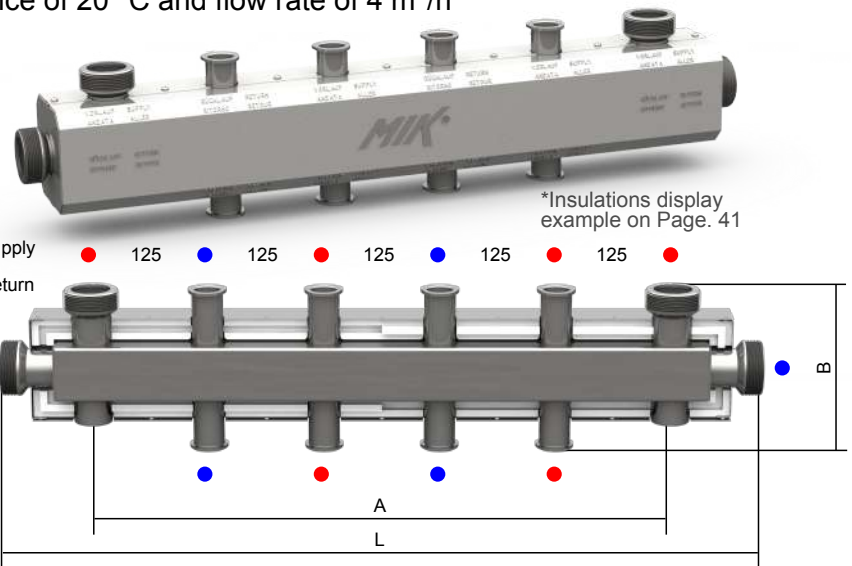

### Technical specification

Boiler connections	DN 32 with external thread G 2"
Consumer connections	DN 25 oval flange for G 1 1/2" nut
Insulation <sub>Heating</sub>	EPS 25 mm (EN 13501-1 E)
Insulation <sub>Cooling</sub>	FEF 19 mm (EN 13501-1 B,s3,d0)
Max. working temperature <sub>EPS</sub>	90 °C
Max. working temperature <sub>FEF</sub>	85 °C
Max. working pressure	6 bar
K <sub>vs</sub> value	22,2
Connections distance	125 mm
Installation height, B	175 mm
Insulation height	115 mm
Produced acc.	2014/68/EU

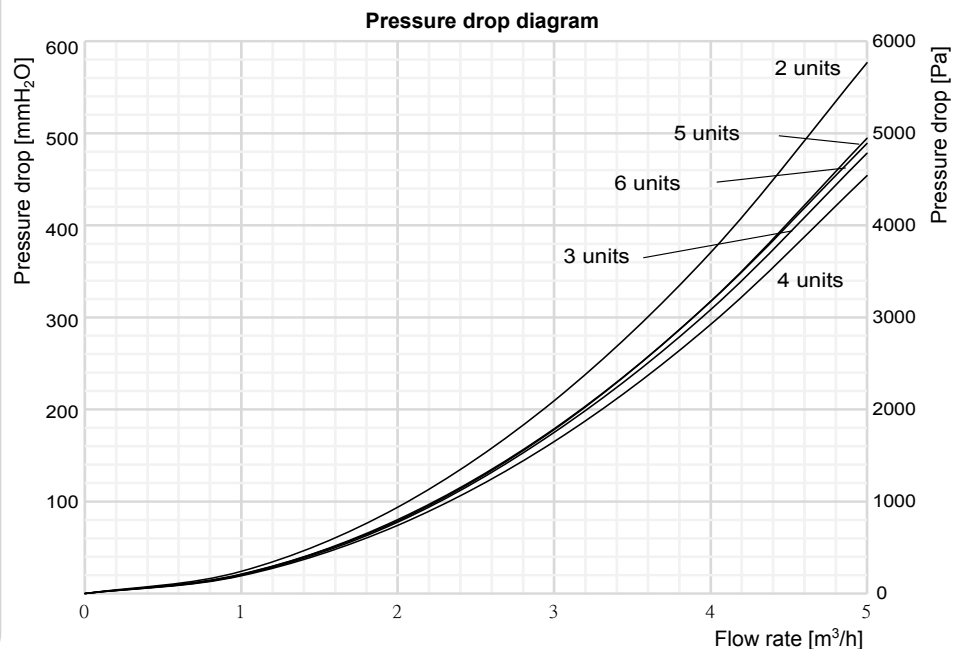

Type		Built-in length L [mm]	Offset of supports A [mm]	Consumer units	Code -heating*	Code -cooling*
	HV 90/125-4	820	625	2 - 4	<b>840 204</b>	<b>840 204 1</b>
	HV 90/125-6	1070	875	4 - 6	<b>840 206</b>	<b>840 206 1</b>

### MIK Wall bracket LU-HV 100-150

- 100 or 150 mm distance from manifold centre to wall
- Galvanized (HRN EN ISO 2081) and chromated (DIN 50962)
- The kit includes screws, dowels, washers and damping elements
- Pack contents 2 pcs.
- Code: **840 012**



## Combined supply-return manifold DN32, HVI 90/125

Up to 90 kW output at a temperature difference of 20 °C and flow rate of 4 m<sup>3</sup>/h

- 2 to 6 heating/cooling circuits
- Left and right boiler connections
- Upper and lower consumer connections
- Supply and return connections located side by side
- Compact construction with integrated supply and return
- Supply and return chambers thermally separated
- Material: S235 carbon steel
- Zinc flake coated chambers flZn-nc-480h acc. DIN EN ISO 10683
- Insulation for heating or cooling with 0,6 mm galvanised sheet steel jacket
- Supply and return markings stamped into sheet steel jacket



\*Insulations display example on Page. 41

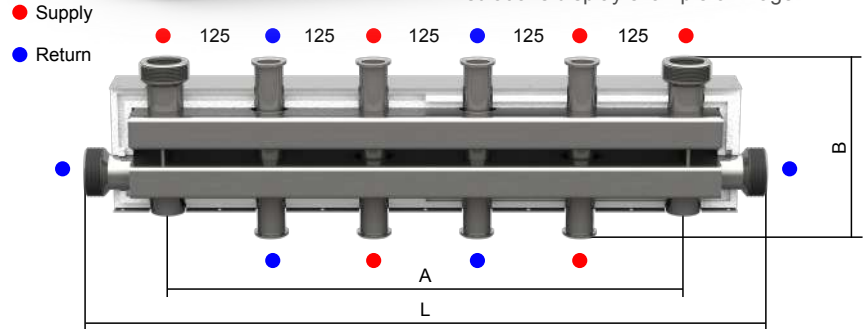



### Technical specification

Boiler connections	DN 32 with external thread G 2"
Consumer connections	DN 25 oval flange for G 1 1/2" nut
Insulation <sub>Heating</sub>	EPS 25 mm (EN 13501-1 E)
Insulation <sub>Cooling</sub>	FEF 19 mm (EN 13501-1 B,s3,d0)
Max. working temperature <sub>EPS</sub>	90 °C
Max. working temperature <sub>FEF</sub>	85 °C
Max. working pressure	6 bar
K <sub>vs</sub> value	28,5
Connections distance	125 mm
Installation height, B	215 mm
Insulation height	155 mm
Produced acc.	2014/68/EU

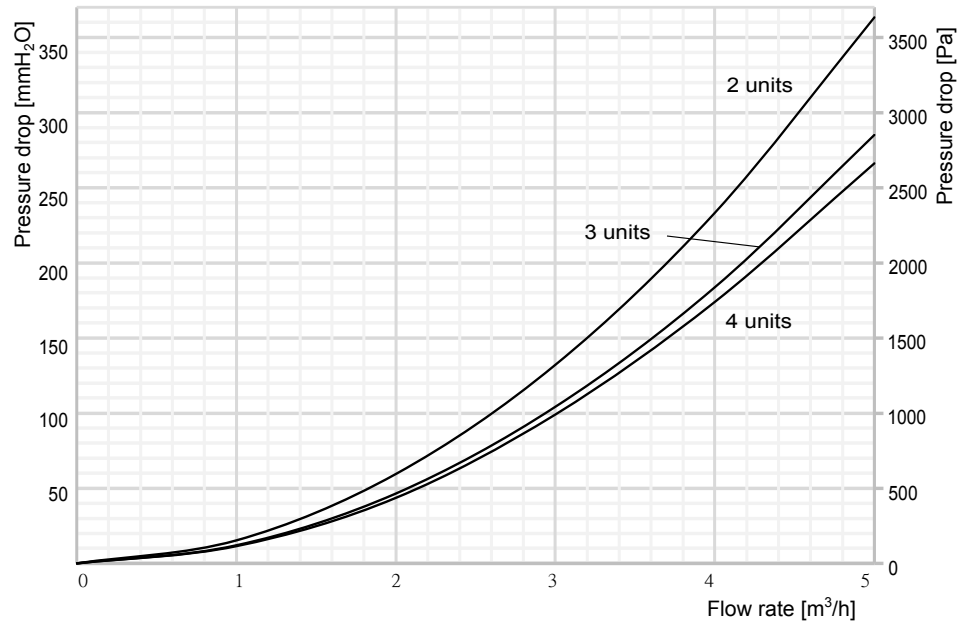
Pressure drop diagram



Type

Type	Built-in length L [mm]	Offset of supports A [mm]	Consumer units	Code -heating*	Code -cooling*
 HVI 90/125-4	820	625	2-4	<b>841 304</b>	<b>841 304 1</b>
 HVI 90/125-6	1070	875	4-6	<b>841 306</b>	<b>841 306 1</b>

### MIK Wall bracket LU-HV 100-150

- 100 or 150 mm distance from manifold centre to wall
- Galvanized (HRN EN ISO 2081) and chromated (DIN 50962)
- The kit includes screws, dowels, washers and damping elements
- Pack contents 2 pcs.
- Code: **840 012**



## Hydraulic separator DN32, HW 60/375 OF

Flow rates up to 4 m<sup>3</sup>/h

- Material: S235 carbon steel
- Zinc flake coated chamber flZn-nc-480h acc. DIN EN ISO 10683
- Insulation for heating or cooling with 0,6 mm galvanised sheet steel jacket
- Supply/return and boiler/consumer markings stamped into sheet steel jacket
- Bleeding and flushing/filling/emptying connections
- Temperature sensor and magnetic separator connections

### Technical specification

Boiler connections	DN 32 oval flange for G 2" nut
Consumer connections	DN 32 oval flange for G 2" nut
Insulation <sub>Heating</sub>	EPS 25 mm (EN 13501-1 E)
Insulation <sub>Cooling</sub>	FEF 19 mm (EN 13501-1 B,s3,d0)
Max. working temperature <sub>EPS</sub>	90 °C
Max. working temperature <sub>FEF</sub>	85 °C
Max. working pressure	6 bar
Volume	1,4 l
Temperature sensor	internal thread G ½"
Bleeding	internal thread G ½"
Flushing/filling/emptying	internal thread G ½"
Magnetic dirt separator	internal thread G ½"
Pressure drop at max. recirculation	< 800 Pa

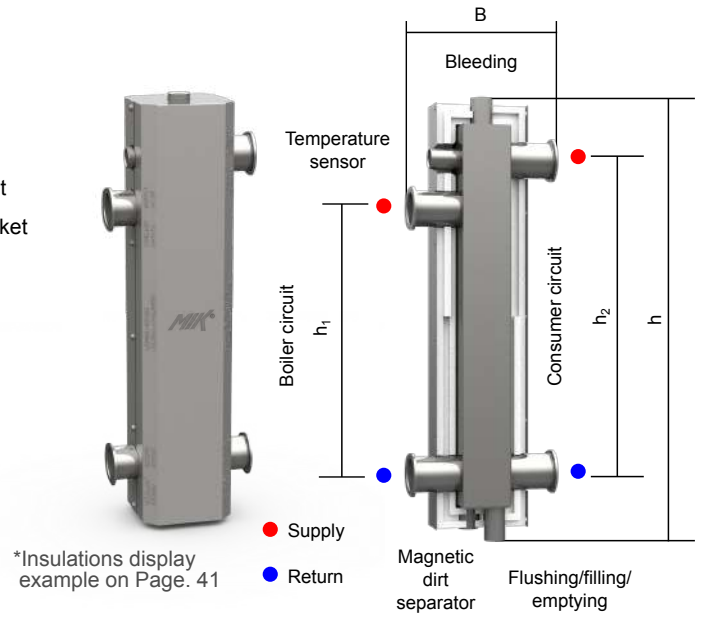

\*Insulations display example on Page. 41

Type	Built-in height h [mm]	Built-in width B [mm]	Offset h <sub>1</sub> [mm]	Offset h <sub>2</sub> [mm]	Code -heating* -cooling*
HW 60/375 OF	522	175	315	375	<b>850 015</b> <b>850 015 1</b>

## MIK Wall brackets H-HV

- 100 or 150 mm separator centre distance to wall
- Galvanized (HRN EN ISO 2081) and chromated (DIN 50962)
- The kit includes screws and dowels
- Pack contents 2 pcs.
- Code: **840 007** (100 mm)  
**840 008** (150 mm)



## Installation recommendation:

- Left mounting
- HW 60/375 OF, boiler manifold HV 90/125-4 and connection tube VR 32
- Installation with 4 pump sets

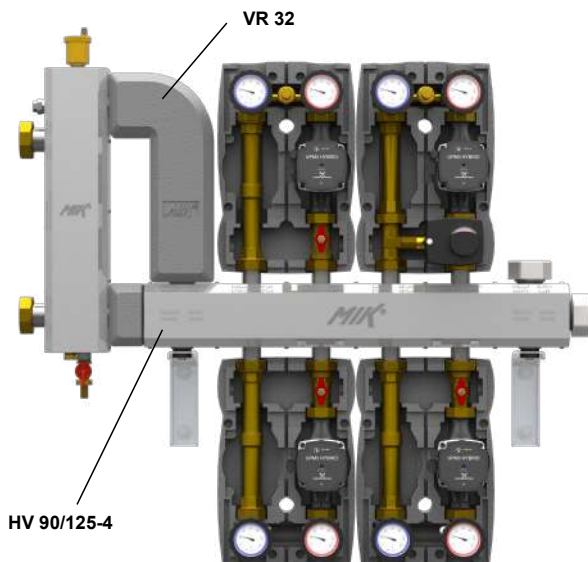

- Right mounting
- HW 60/375 OF, boiler manifold MIK HVI 90/125-4 and connection tube VR 32 L = 235,5
- Installation with 3 pump sets

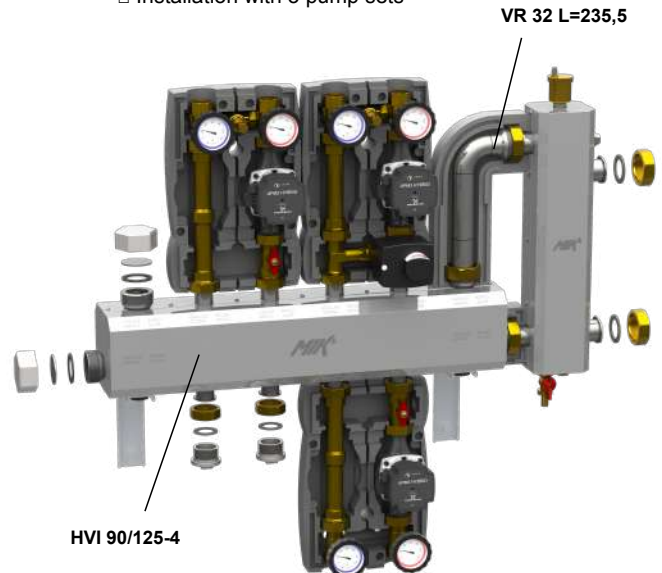

Code



### Connection tube VR 32

- Connections: DN 32 with external thread G 2"  
DN 32 oval flange for G 2" nut
- Distance l = 285,5 mm
- Includes polystyrene insulation (EN 13501-1 E)  
for connecting manifold's supply and return



600 086

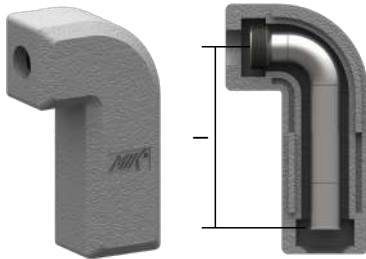

### Connection tube VR 32 L = 235,5

- Connections: DN 32 with external thread G 2"  
DN 32 oval flange for G 2" nut
- Distance l = 235,5 mm
- Includes polystyrene insulation (EN 13501-1 E)  
for connecting manifold's supply (in 4 parts) and return  
(in 2 parts)



600 087

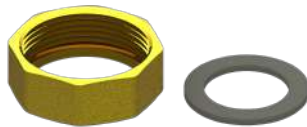

### Union nut 1 1/2" with gasket

- Set:
  - G 1 1/2" union nut
  - Gasket

870 000.14



### Screw plug 1 1/2"

- External thread G 1 1/2"

870 000.16

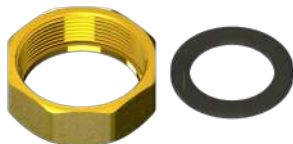

### Union nut 2" with gasket

- Set:
  - G 2" union nut
  - Gasket

871 000.14



### Blank nut cup G 2" with washer and gasket

- Set:
  - G 2" blank nut cap
  - Washer
  - Gasket

KAPA-2"

## Combined supply-return manifold HV 80/200

Up to 120 kW output at a temperature difference of 20 °C and flow rate of 5,3 m<sup>3</sup>/h

- 2 to 6 heating/cooling circuits
- Boiler connections underneath
- Consumer connections above
- Supply and return connections located side by side
- Compact construction with integrated supply and return
- Material: S235 carbon steel
- Zinc flake coated chambers flZn-nc-480h acc. DIN EN ISO 10683
- Insulation for heating or cooling with 0,6 mm galvanised sheet steel jacket
- Supply and return markings stamped into sheet steel jacket
- Chambers filling/emptying connections

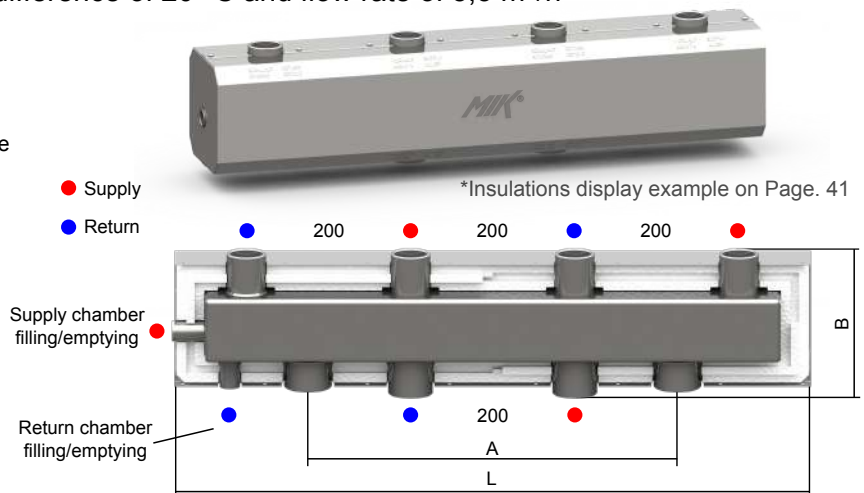

### Technical specification

Boiler connections	internal thread G 1 1/2"
Consumer connections	internal thread G 1 1/4"
Filling/emptying	internal thread G 1/2"
Insulation <sub>Heating</sub>	EPS 35 mm (EN 13501-1 E)
Insulation <sub>Cooling</sub>	FEF 19 mm (EN 13501-1 B,s3,d0)
Max. working temperature <sub>EPS</sub>	90 °C
Max. working temperature <sub>FEF</sub>	85 °C
Max. working pressure	6 bar
K <sub>vs</sub> value	41,6
Connections distance	200 mm
Installation height, B	176 mm
Insulation height	155 mm
Produced acc.	2014/68/EU

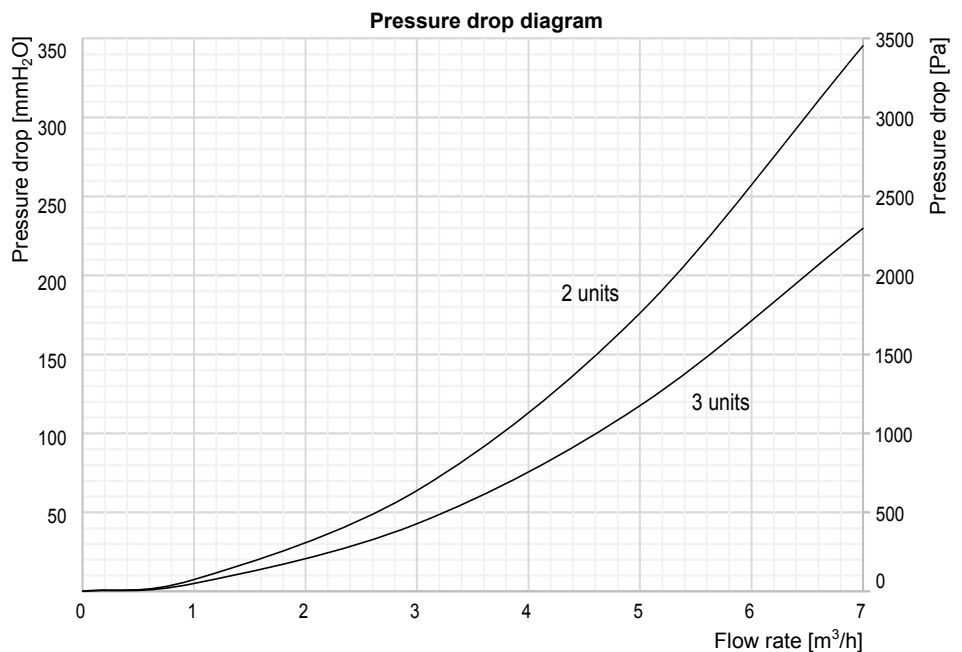

Type	Built-in length L [mm]	Offset of supports A [mm]	Consumer units	Code -heating*	Code -cooling*
HV 80/200-2	775	450	2	841 002	841 002 1
HV 80/200-3	1175	600	3	841 003	841 003 1
HV 80/200-4	1575	1000	4	841 004	841 004 1
HV 80/200-5	1975	1400	5	841 005	841 005 1
HV 80/200-6	2375	1400	6	841 006	841 006 1

### MIK Wall bracket LU-HV 160-220

- 160 or 220 mm distance from manifold centre to wall
- Galvanized (HRN EN ISO 2081) and chromated (DIN 50962)
- The kit includes screws, dowels, washers and damping elements
- Pack contents 2 pcs.
- Code: **840 013**



### MIK Adjustable stands SKL 80

- Adjustable height 450-660 mm or 650-900 mm
- Galvanized (HRN EN ISO 2081) and chromated (DIN 50962)
- The kit includes screws, dowels, washers and damping elements
- Pack contents 1 piece
- Code: **840 015** (450-660 mm)
- Code: **840 016** (650-900 mm)



## Combined supply-return manifold HV 80/200 SU

Up to 120 kW output at a temperature difference of 20 °C and flow rate of 5,3 m<sup>3</sup>/h

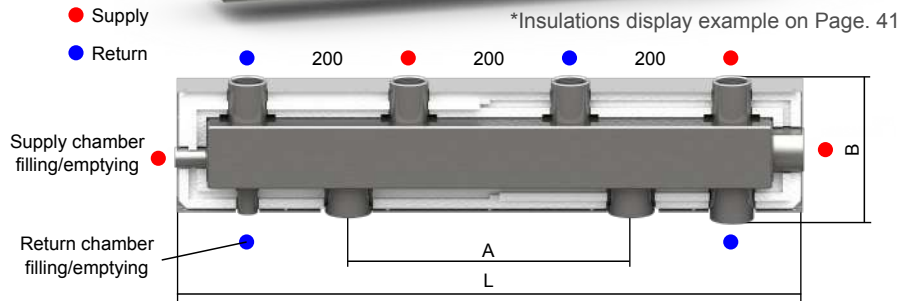

- 2 to 6 heating/cooling circuits
- Boiler connections sideways and underneath
- Consumer connections above
- Supply and return connections located side by side
- Compact construction with integrated supply and return
- Material: S235 carbon steel
- Zinc flake coated chambers flZn-nc-480h acc. DIN EN ISO 10683
- Insulation for heating or cooling with 0,6 mm galvanized sheet steel jacket
- Supply and return markings stamped into sheet steel jacket
- Chambers filling/emptying connections

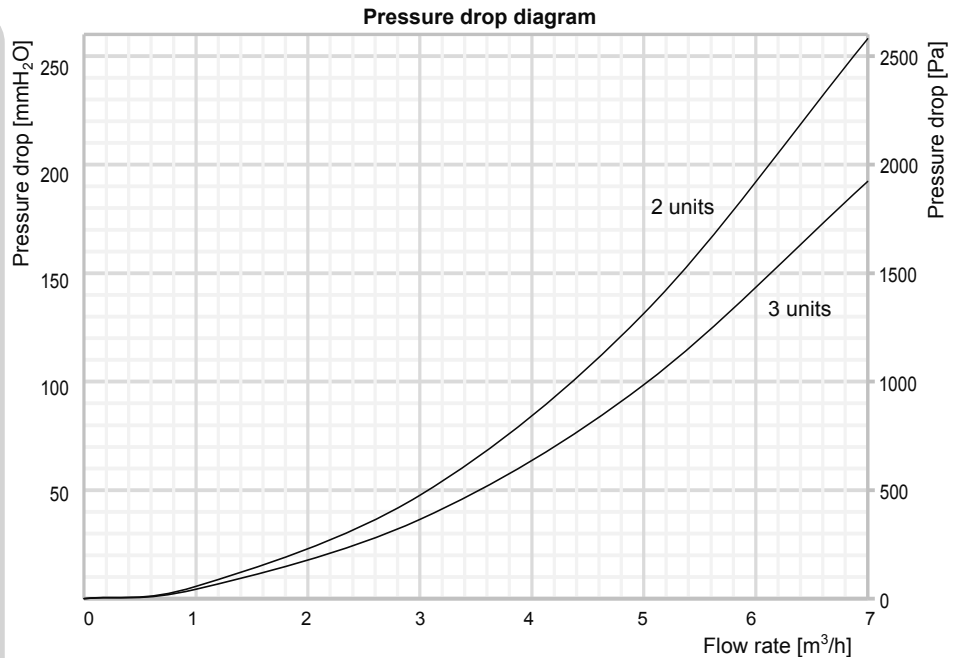

### Technical specification

Boiler connections	internal thread G 1 1/2"
Consumer connections	internal thread G 1 1/4"
Filling/emptying	internal thread G 1/2"
Insulation <sub>Heating</sub>	EPS 35 mm (EN 13501-1 E)
Insulation <sub>Cooling</sub>	FEF 19 mm (EN 13501-1 B,s3,d0)
Max. working temperature <sub>EPS</sub>	90 °C
Max. working temperature <sub>FEF</sub>	85 °C
Max. working pressure	6 bar
K <sub>vs</sub> value	46,3
Connections distance	200 mm
Installation height, B	176 mm
Insulation height	155 mm
Produced acc.	2014/68/EU



Type	Built-in length L [mm]	Offset of supports A [mm]	Consumer units	Code -heating*	Code -cooling*
 HV 80/200 SU-2	775	350	2	<b>842 002</b>	<b>842 002 1</b>
 HV 80/200 SU-3	1175	600	3	<b>842 003</b>	<b>842 003 1</b>
	1575	1000	4	<b>842 004</b>	<b>842 004 1</b>
	1975	1400	5	<b>842 005</b>	<b>842 005 1</b>
	2375	1400	6	<b>842 006</b>	<b>842 006 1</b>

### MIK Wall bracket LU-HV 160-220

- 160 or 220 mm distance from manifold centre to wall
- Galvanized (HRN EN ISO 2081) and chromated (DIN 50962)
- The kit includes screws, dowels, washers and damping elements
- Pack contents 2 pcs.
- Code: **840 013**



### MIK Adjustable stands SKL 80

- Adjustable height 450-660 mm or 650-900 mm
- Galvanized (HRN EN ISO 2081) and chromated (DIN 50962)
- The kit includes screws, dowels, washers and damping elements
- Pack contents 1 piece
- Code: **840 015** (450-660 mm)
- **840 016** (650-900 mm)





## Combined supply-return manifold HV 80/125/190 DN 25

Up to 120 kW output at a temperature difference of 20 °C and flow rate of 5,3 m<sup>3</sup>/h

- 2 to 6 heating/cooling circuits
- Material: S235 carbon steel
- Compact construction with integrated supply and return
- Boiler connections underneath
- Consumer connections above
- Supply and return connections located side by side
- Zinc flake coated chambers flZn-nc-480h acc. DIN EN ISO 10683
- Insulation for heating or cooling with 0,6 mm galvanised sheet steel jacket
- Supply and return markings stamped into sheet steel jacket



\*Insulations display example on Page. 41

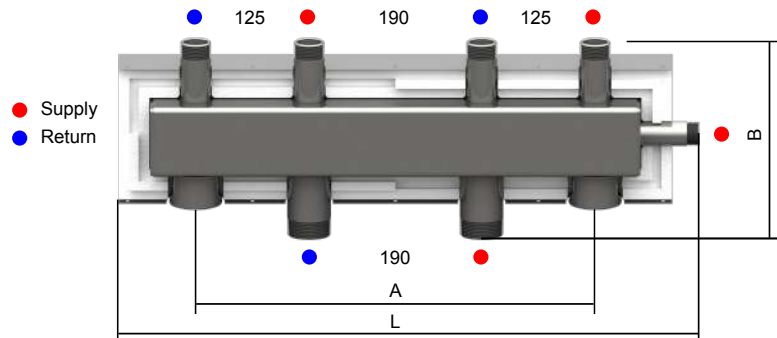

### Technical specification

Boiler connections	external thread R 1 1/2"	Max. working temperature <sub>FEF</sub>	85 °C
Consumer connections	external thread R 1"	Max. working pressure	6 bar
Side connection	external thread R 3/4"	Connections distance	125/190 mm
Insulation <sub>Heating</sub>	EPS 35 mm (EN 13501-1 E)	Installation height, B	220 mm
Insulation <sub>Cooling</sub>	FEF 19 mm (EN 13501-1 B,s3,d0)	Insulation height	155 mm
Max. working temperature <sub>EPS</sub>	90 °C	Produced acc.	2014/68/EU

Type	Built-in length L [mm]	Offset of supports A [mm]	Consumer units	Code -heating*	Code -cooling*
HV 80/125/190-2 DN25	640	440	2	<b>843 302</b>	<b>843 302 1</b>
HV 80/125/190-3 DN25	955	505	3	<b>843 303</b>	<b>843 303 1</b>
HV 80/125/190-4 DN25	1270	630	4	<b>843 304</b>	<b>843 304 1</b>
HV 80/125/190-5 DN25	1585	630	5	<b>843 305</b>	<b>843 305 1</b>
HV 80/125/190-6 DN25	1900	820	6	<b>843 306</b>	<b>843 306 1</b>
HV 80/125/190-6 DN25	2215	1135	7	<b>843 307</b>	<b>843 307 1</b>

### MIK Wall bracket LU-HV 160-220

- 160 or 220 mm distance from manifold centre to wall
- Galvanized (HRN EN ISO 2081) and chromated (DIN 50962)
- The kit includes screws, dowels, washers and damping elements
- Pack contents 2 pcs.
- Code: **840 013**



### MIK Adjustable stands SKL 80

- Adjustable height 450-660 mm or 650-900 mm
- Galvanized (HRN EN ISO 2081) and chromated (DIN 50962)
- The kit includes screws, dowels, washers and damping elements
- Pack contents 1 piece
- Code: **840 015** (450-660 mm)
- **840 016** (650-900 mm)



## Hydraulic separator HW 80/190-1 1/2"

Flow rates up to 6 m<sup>3</sup>/h

- Material: S235 carbon steel
- Zinc flake coated chamber fZn-nc-480h acc. DIN EN ISO 10683
- Insulation for heating or cooling with 0,6 mm galvanised sheet steel jacket
- Supply/return and boiler/consumer markings stamped into sheet steel jacket
- Temperature sensor connection

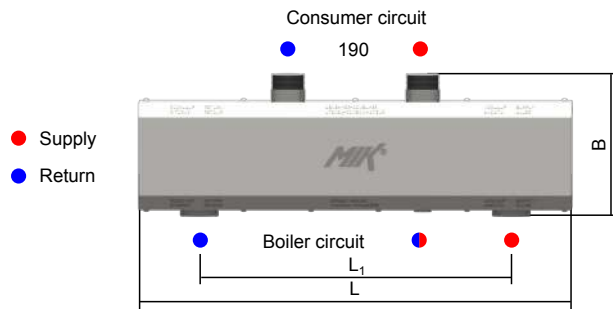

\*Insulations display example on Page. 41

### Technical specification

Boiler connections	internal thread G 1 1/2"
Consumer connections	external thread R 1 1/2"
Insulation <sub>Heating</sub>	EPS 35 mm (EN 13501-1 E)
Insulation <sub>Cooling</sub>	FEF 19 mm (EN 13501-1 B,s3,d0)
Max. working temperature <sub>EPS</sub>	90 °C
Max. working temperature <sub>FEF</sub>	85 °C
Max. working pressure	6 bar
Volume	2,7 l
Temperature sensor	internal thread G 1/2"

Type	Built-in length L [mm]	Distance L <sub>1</sub> [mm]	Height B [mm]	Code -heating* -cooling*
HW 80/190-1 1/2"	610	440	201	<b>850 014</b> <b>850 014 1</b>

## Hydraulic separator HW 80/190-1 1/2" and boiler manifold HV 80/125 /190-2 DN 25 with heating circuit modules:

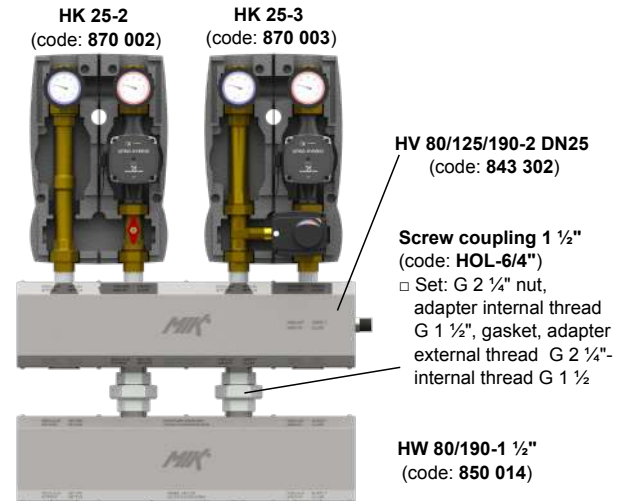

## Hydraulic separator HW 80/200-1 1/2"

Flow rates up to 6 m<sup>3</sup>/h

- Material: S235 carbon steel
- Zinc flake coated chamber fZn-nc-480h acc. DIN EN ISO 10683
- Insulation for heating or cooling with 0,6 mm galvanised sheet steel jacket
- Supply/return and boiler/consumer markings stamped into sheet steel jacket
- Temperature sensor connection



\*Insulations display example on Page. 41

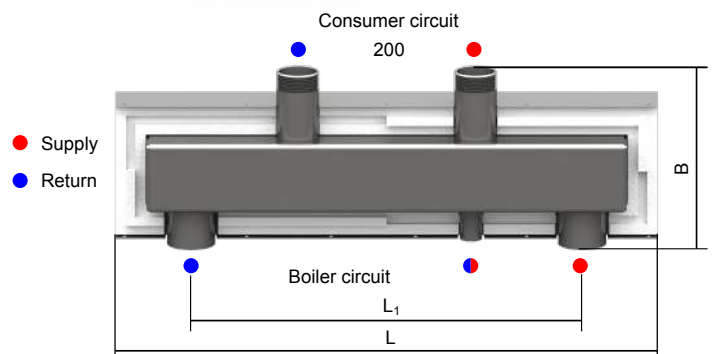

Type	Built-in length L [mm]	Distance L <sub>1</sub> [mm]	Height B [mm]	Code -heating* -cooling*
HW 80/200-1 1/2"	610	440	201	<b>850 016</b> <b>850 016 1</b>

## MIK Wall brackets H-HW

- 160 or 220 mm distance from separator centre to wall
- Galvanized (HRN EN ISO 2081) and chromated (DIN 50962)
- The kit includes screws and dowels
- Pack contents 2 pcs.
- Code: **850 101** (160 mm)  
**850 102** (220 mm)



## Hydraulic separator HW 80/400

Flow rates up to 7 m<sup>3</sup>/h

- Material: S235 carbon steel
- Zinc flake coated chamber flZn-nc-480h acc. DIN EN ISO 10683
- Insulation for heating or cooling with 0,6 mm galvanised sheet steel jacket
- Supply/return and boiler/consumer markings stamped into sheet steel jacket
- Bleeding and flushing/filling/emptying connections
- Temperature sensor connection

### Technical specification

Boiler connections	internal thread G 1 1/2"
Consumer connections	internal thread G 1 1/2"
Insulation <sub>Heating</sub>	EPS 35 mm (EN 13501-1 E)
Insulation <sub>Cooling</sub>	FEF 19 mm (EN 13501-1 B,s3,d0)
Max. working temperature <sub>EPS</sub>	90 °C
Max. working temperature <sub>FEF</sub>	85 °C
Max. working pressure	6 bar
Volume	2,7 l
Bleeding	internal thread G 1/2"
Temperature sensor	internal thread G 1/2"
Flushing/filling/emptying	internal thread G 1/2"

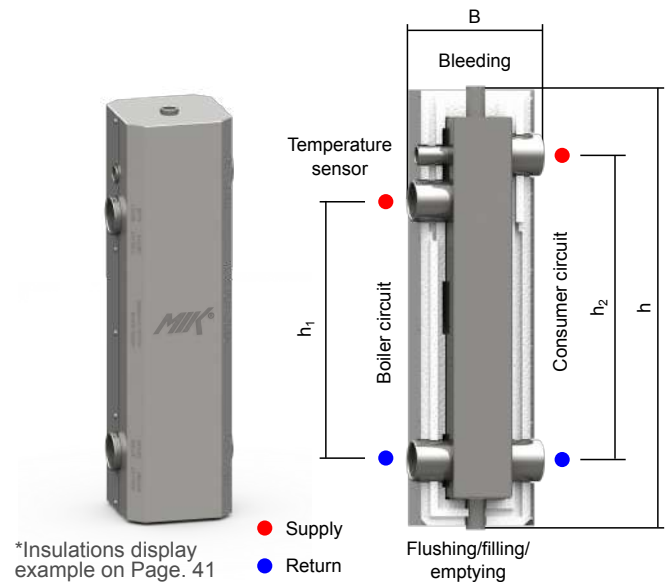

\*Insulations display example on Page. 41

Type	Built-in height $h$ [mm]	Built-in width $B$ [mm]	Boiler connections distance $h_1$ [mm]	Consumer connections distance $h_2$ [mm]	Code -heating* -cooling*
HW 80/400	580	172	340	400	<b>850 010</b> <b>850 010 1</b>

## Hydraulic separator HW 80

Flow rates up to 7 m<sup>3</sup>/h

- Material: S235 carbon steel
- Zinc flake coated chamber flZn-nc-480h acc. DIN EN ISO 10683
- Insulation for heating or cooling with 0,6 mm galvanised sheet steel jacket
- Supply/return and boiler/consumer markings stamped into sheet steel jacket

### Technical specification

Boiler connections	internal thread G 1 1/2"
Consumer connections	internal thread G 1 1/2"
Insulation <sub>Heating</sub>	EPS 35 mm (EN 13501-1 E)
Insulation <sub>Cooling</sub>	FEF 19 mm (EN 13501-1 B,s3,d0)
Max. working temperature <sub>EPS</sub>	90 °C
Max. working temperature <sub>FEF</sub>	85 °C
Max. working pressure	6 bar
Volume	3,8 l

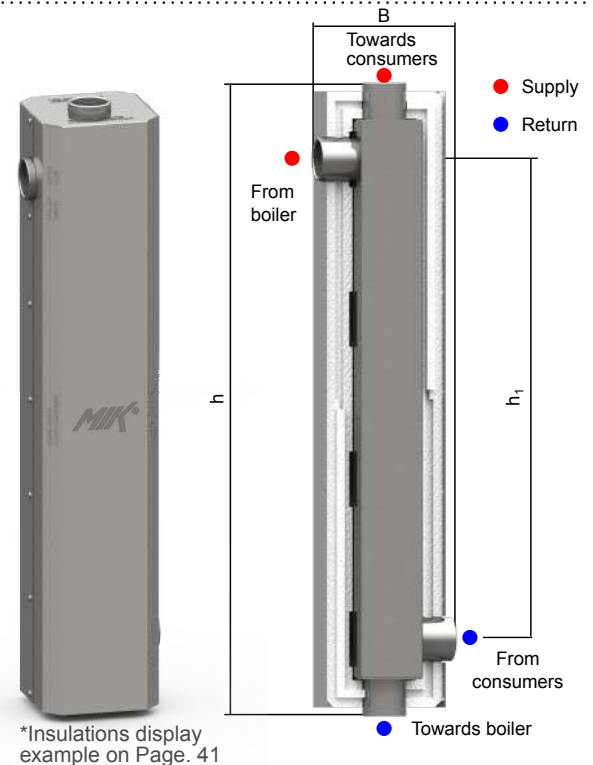

\*Insulations display example on Page. 41

Type	Built-in height $h$ [mm]	Built-in width $B$ [mm]	Connections distance $h_1$ [mm]	Code -heating*	Code -cooling*
HW 80	792	172	600	<b>850 006</b>	<b>850 006 1</b>

## MIK Wall brackets H-HW

- 160 or 220 mm distance from separator centre to wall
- Galvanized (HRN EN ISO 2081) and chromated (DIN 50962)
- The kit includes screws and dowels
- Pack contents 2 pcs.
- Code: **850 101** (160 mm)
- 850 102** (220 mm)



## Boiler safety unit with insulation SG/I 200



- Mounting assembly for self-contained heating systems up to 200 kW
- Ready for use - equipped with: manometer with automatic shut-off valve, quick air bleeding system with automatic shut-off valve and safety valve 3 bar
- EPS insulation 20 mm (EN 13501-1 E)
- Boiler connection: internal thread G 1"

Code

860 200

## Steel chamber K4a for boiler safety unit SG/I 200



- Mounting assembly for self-contained heating systems up to 200 kW
- Manometer and bleeding valve connections: internal thread G 3/8"
- Safety valve connection: external thread R 1"
- Boiler connection: internal thread G 1"

860 214

## Boiler safety unit with insulation SG/I 200 DD



- Mounting assembly for self-contained heating systems up to 200 kW
- Ready for use - equipped with: manometer with automatic shut-off valve, quick air bleeding system with automatic shut-off valve and safety valve 3 bar
- EPS insulation 20 mm (EN 13501-1 E)
- Boiler connection: external thread R 1"

860 200 DD

## Steel chamber K4a DD for boiler safety unit SG/I 200 DD

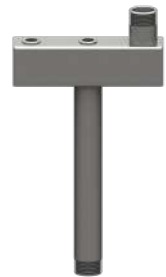

- Mounting assembly for self-contained heating systems up to 200 kW
- Manometer and bleeding valve connections: internal thread G 3/8"
- Safety valve connection: external thread R 1"
- Boiler connection: external thread R 1"

860 314

## EPS insulation for safety units (K2a-K5a)



- EPS insulation 20 mm (EN 13501-1 E) for MIK boiler safety units

IZOLEPS-SG

## Safety valve SVH/E 1" 3 bar



- For heating systems with output up to 200 kW
- Maximum pressure: 3 bar
- Inlet connection: internal thread G 1"
- Outlet connection: internal thread G 1 1/4"

SVH/E 1-3B

- HV 80/125-3 MIK boiler manifold with caps 2" (843 103)
- HW 80/570 MIK hydraulic separator (600 080)
- HK 32-2 Heating circuit module (871 002)
- HK 32-3 Heating circuit module (871 003)
- HK 25-3 Heating circuit module (870 003)
- EWK 2 MIK Multi-function unit for expansion tank for sanitary system (860 135)
- SG/I 350 MIK Boiler safety unit (860 350)
- HOP2.5 MIK Horizontal air vent vessel (830 001)
- VR2 Connection tube with 2" screw couplings (600 085)
- Adapter for HK 25 (870 060)
- Air vent valve 3/8" (MINIVENT MV10R)
- H-HW 160 MIK Wall bracket (850 101)
- LU-HV 160-220 MIK Wall bracket (840 013)
- 1 Solid fuel firing boiler
- 2 Gas boiler
- 3 Drain valve
- 4 Temperature sensor
- 5 Regulation
- 6 Radiator
- 7 Underfloor heating
- 8 Use of sanitary water
- 9 Sanitary water tank
- 10 Room thermostat
- 11 Expansion tank
- 12 Water supply

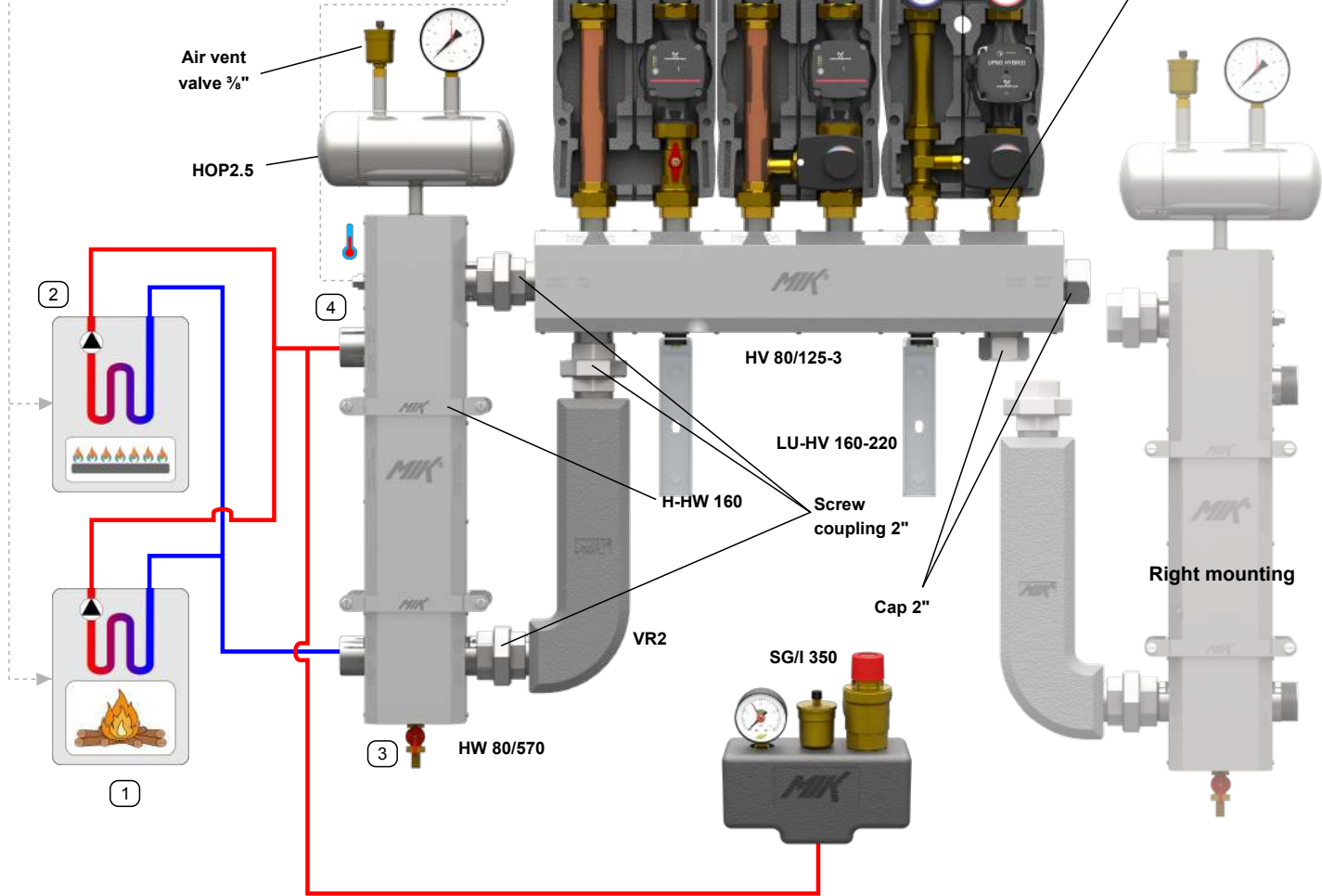
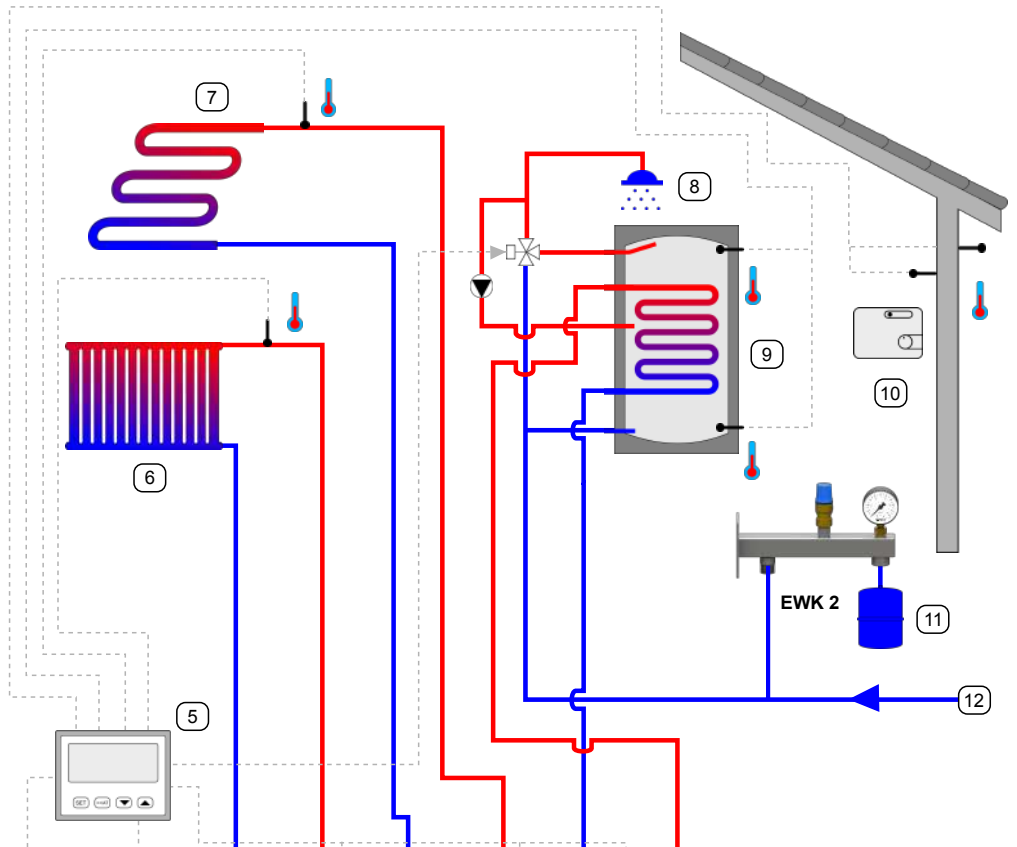

## Combined supply-return manifold HV 80/125

Up to 165 kW output at a temperature difference of 20 °C and flow rate of 7,3 m<sup>3</sup>/h

- 2 to 6 heating/cooling circuits
- Boiler connections side and underneath (left and right mounting)
- Consumer connections above
- Supply and return connections located side by side
- Compact construction with integrated supply and return
- Material: S235 carbon steel
- Zinc flake coated chambers flZn-nc-480h acc. DIN EN ISO 10683
- Insulation for heating or cooling with 0,6 mm galvanised sheet steel jacket
- Supply and return markings stamped into sheet steel jacket
- Equipped with two blank nut caps 2"



\*Insulations display example on Page. 41

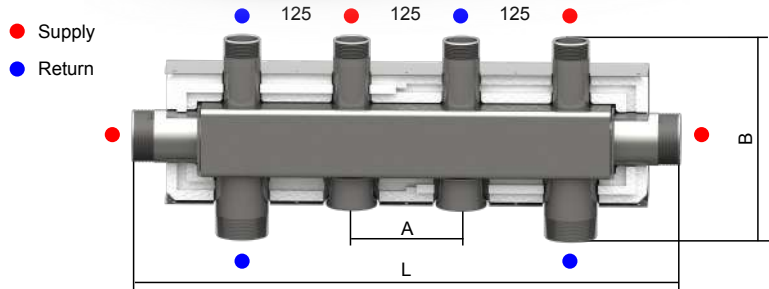

Pressure drop diagram

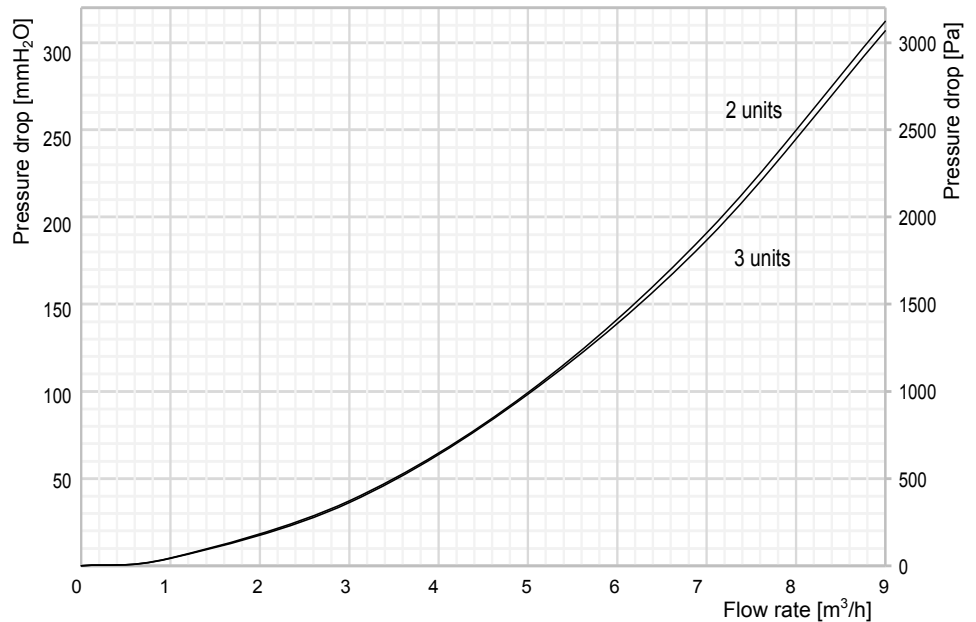

### Technical specification

Boiler connections	external thread R 2"
Consumer connections	external thread R 1 1/4"
Insulation <sub>Heating</sub>	EPS 35 mm (EN 13501-1 E)
Insulation <sub>Cooling</sub>	FEF 19 mm (EN 13501-1 B,s3,d0)
Max. working temperature <sub>EPS</sub>	90 °C
Max. working temperature <sub>FEF</sub>	85 °C
Max. working pressure	6 bar
K <sub>vs</sub> value	49,9
Connections distance	125 mm
Installation height, B	230 mm
Insulation height	155 mm
Produced acc.	2014/68/EU

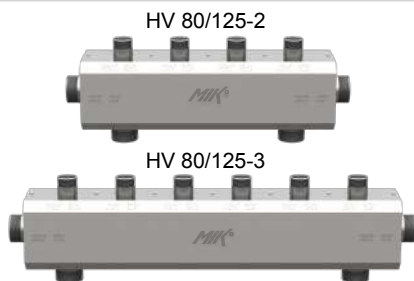

Type	Built-in length L [mm]	Offset of supports A [mm]	Consumer units	Code -heating*	Code -cooling*
HV 80/125-2	625	125	2	<b>843 102</b>	<b>843 102 1</b>
HV 80/125-3	875	375	3	<b>843 103</b>	<b>843 103 1</b>
HV 80/125-4	1125	625	4	<b>843 104</b>	<b>843 104 1</b>
HV 80/125-5	1375	625	5	<b>843 105</b>	<b>843 105 1</b>
HV 80/125-6	1625	875	6	<b>843 106</b>	<b>843 106 1</b>

### MIK Wall bracket LU-HV 160-220

- 160 or 220 mm distance from manifold centre to wall
- Galvanized (HRN EN ISO 2081) and chromated (DIN 50962)
- The kit includes screws, dowels, washers and damping elements
- Pack contents 2 pcs.
- Code: **840 013**



### MIK Adjustable stands SKL 80

- Adjustable height 450-660 mm or 650-900 mm
- Galvanized (HRN EN ISO 2081) and chromated (DIN 50962)
- The kit includes screws, dowels, washers and damping elements
- Pack contents 1 piece
- Code: **840 015** (450-660 mm)  
**840 016** (650-900 mm)



## Hydraulic separator HW 80/570

Flow rates up to 8 m<sup>3</sup>/h

- Material: S235 carbon steel
- Zinc flake coated chamber flZn-nc-480h acc. DIN EN ISO 10683
- Insulation for heating or cooling with 0,6 mm galvanised sheet steel jacket
- Supply/return and boiler/consumer markings stamped into sheet steel jacket
- Bleeding and flushing/filling/emptying connections
- Temperature sensor connection

### Technical specification

Boiler connections	external thread R 2"
Consumer connections	external thread R 2"
Insulation <sub>Heating</sub>	EPS 35 mm (EN 13501-1 E)
Insulation <sub>Cooling</sub>	FEF 19 mm (EN 13501-1 B,s3,d0)
Max. working temperature <sub>EPS</sub>	90 °C
Max. working temperature <sub>FEF</sub>	85 °C
Max. working pressure	6 bar
Volume	3,8 l
Bleeding	internal thread G ½"
Temperature sensor	internal thread G ½"
Flushing/filling/emptying	internal thread G ½"

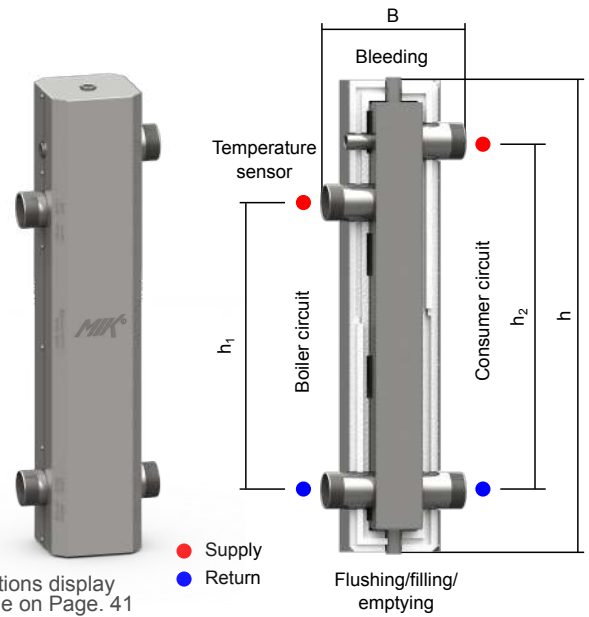

\*Insulations display example on Page. 41

Type	Built-in height h [mm]	Built-in width B [mm]	Boiler connections distance h <sub>1</sub> [mm]	Consumer connections distance h <sub>2</sub> [mm]	Code -heating* -cooling*
HW 80/570	778	230	470	570	<b>600 080</b> <b>600 080 1</b>

## Hydraulic separator HW 80/570A

Flow rates up to 8 m<sup>3</sup>/h

- Material: S235 carbon steel
- Zinc flake coated chamber flZn-nc-480h acc. DIN EN ISO 10683
- Insulation for heating or cooling with 0,6 mm galvanised sheet steel jacket
- Supply/return and boiler/consumer markings stamped into sheet steel jacket
- Flushing/filling/emptying and temperature sensor connections
- Boiler safety unit connection

### Technical specification

Boiler connections	external thread R 2"
Consumer connections	external thread R 2"
Insulation <sub>Heating</sub>	EPS 35 mm (EN 13501-1 E)
Insulation <sub>Cooling</sub>	FEF 19 mm (EN 13501-1 B,s3,d0)
Max. working temperature <sub>EPS</sub>	90 °C
Max. working temperature <sub>FEF</sub>	85 °C
Max. working pressure	6 bar
Volume	3,8 l
Boiler safety unit	external thread G 1 ¼"
Temperature sensor	internal thread G ½"
Flushing/filling/emptying	internal thread G ½"

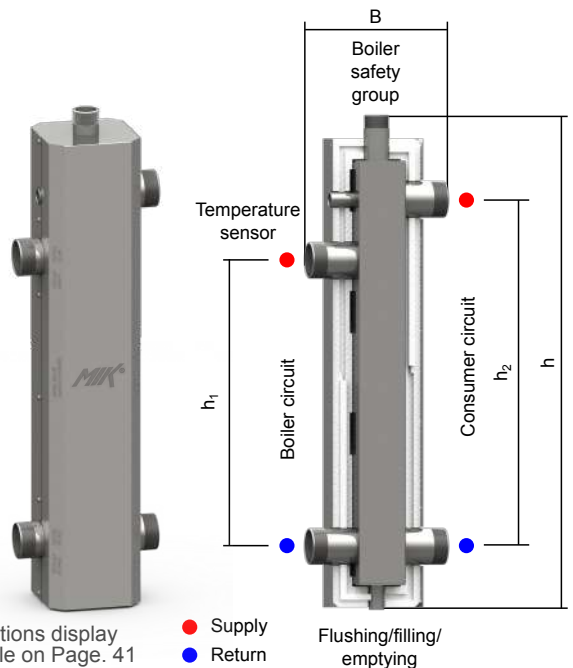

\*Insulations display example on Page. 41

Type	Built-in height h [mm]	Built-in width B [mm]	Boiler connections distance h <sub>1</sub> [mm]	Consumer connections distance h <sub>2</sub> [mm]	Code -heating* -cooling*
HW 80/570A	813	230	470	570	<b>600 081</b> <b>600 081 1</b>

## MIK Wall brackets H-HW

- 160 or 220 mm distance from separator centre to wall
- Galvanized (HRN EN ISO 2081) and chromated (DIN 50962)
- The kit includes screws and dowels
- Pack contents 2 pcs.
- Code: **850 101** (160 mm)  
**850 102** (220 mm)



## Boiler safety unit with insulation SG/I 350



- Mounting assembly for self-contained heating systems up to 350 kW
- Ready for use - equipped with: manometer with automatic shut-off valve, quick air bleeding system with automatic shut-off valve and safety valve 3 bar
- EPS insulation 20 mm (EN 13501-1 E)
- Boiler connection: internal thread G 1 1/4"

Code

**860 350**

## Steel chamber K5a for boiler safety unit SG/I 350



- Mounting assembly for self-contained heating systems up to 350 kW
- Manometer and bleeding valve connections: internal thread G 3/8"
- Safety valve connection: external thread R 1 1/4"
- Boiler connection: internal thread G 1 1/4"

**860 215**

## Boiler safety unit with insulation SG/I 350 DD



- Mounting assembly for self-contained heating systems up to 350 kW
- Ready for use - equipped with: manometer with automatic shut-off valve, quick air bleeding system with automatic shut-off valve and safety valve 3 bar
- EPS insulation 20 mm (EN 13501-1 E)
- Boiler connection: external thread R 1 1/4"

**860 350 DD**

## Steel chamber K5a DD for boiler safety unit SG/I 350 DD



- Mounting assembly for self-contained heating systems up to 350 kW
- Manometer and bleeding valve connections: internal thread G 3/8"
- Safety valve connection: external thread R 1 1/4"
- Boiler connection: external thread R 1 1/4"

**860 315**

## Safety valve SVH/E 1 1/4" 3 bar



- For heating systems with output up to 350 kW
- Maximum pressure: 3 bar
- Inlet connection: internal thread G 1 1/4"
- Outlet connection: internal thread G 1 1/2"

**SVH/E 5/4-3B**

## Connection tube VR 2"



- Connections: external thread R 2"
- Distance l = 422 mm
- Includes insulation (EN 13501-1 E) and 3 screw couplings 2"

**600 085**

## Screw coupling G 2"



- Set:
  - Adapter external thread G 2 3/4"/internal thread G 2"
  - Gasket
  - Adapter internal thread G 2"
  - G 2 3/4" nut

**HOL-2"**

## Blank nut cap G 2"



- G 2" cap

**HOLKAPA-2"**

## Adapter for DN25 pump units



- Adapter DN32 to DN25 for connecting HK 25 pump units
- Set:
  - Gasket
  - Safety ring
  - Union nut G 1 1/2"
  - Reduction G 1 1/4" on 1 1/2" nut

**870 060**



Display example of insulations shown on boiler manifold HV 60/125-3 for heating and cooling.

## Insulation for heating - EPS

- EPS insulation 25mm (35mm)
- Max. working temperature: 90°C
- Thermal Conductivity:  $\lambda = 0.037 \text{ W/(m}\cdot\text{K)}$  at +20°C
- Fire Classification: E according to EN 13501-1

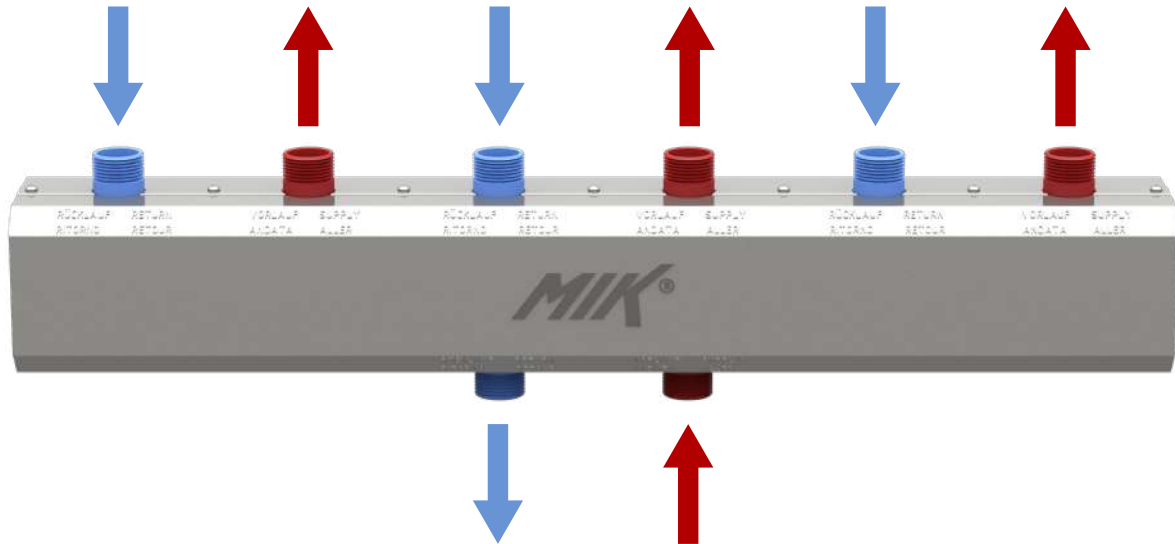

## Insulation for cooling - FEF

- FEF insulation 19mm
- Max. working temperature: 85°C
- Thermal Conductivity:  $\lambda = 0.035 \text{ W/(m}\cdot\text{K)}$  at +20°C
- Fire Classification: B, s3, d0 according to EN 13501-1

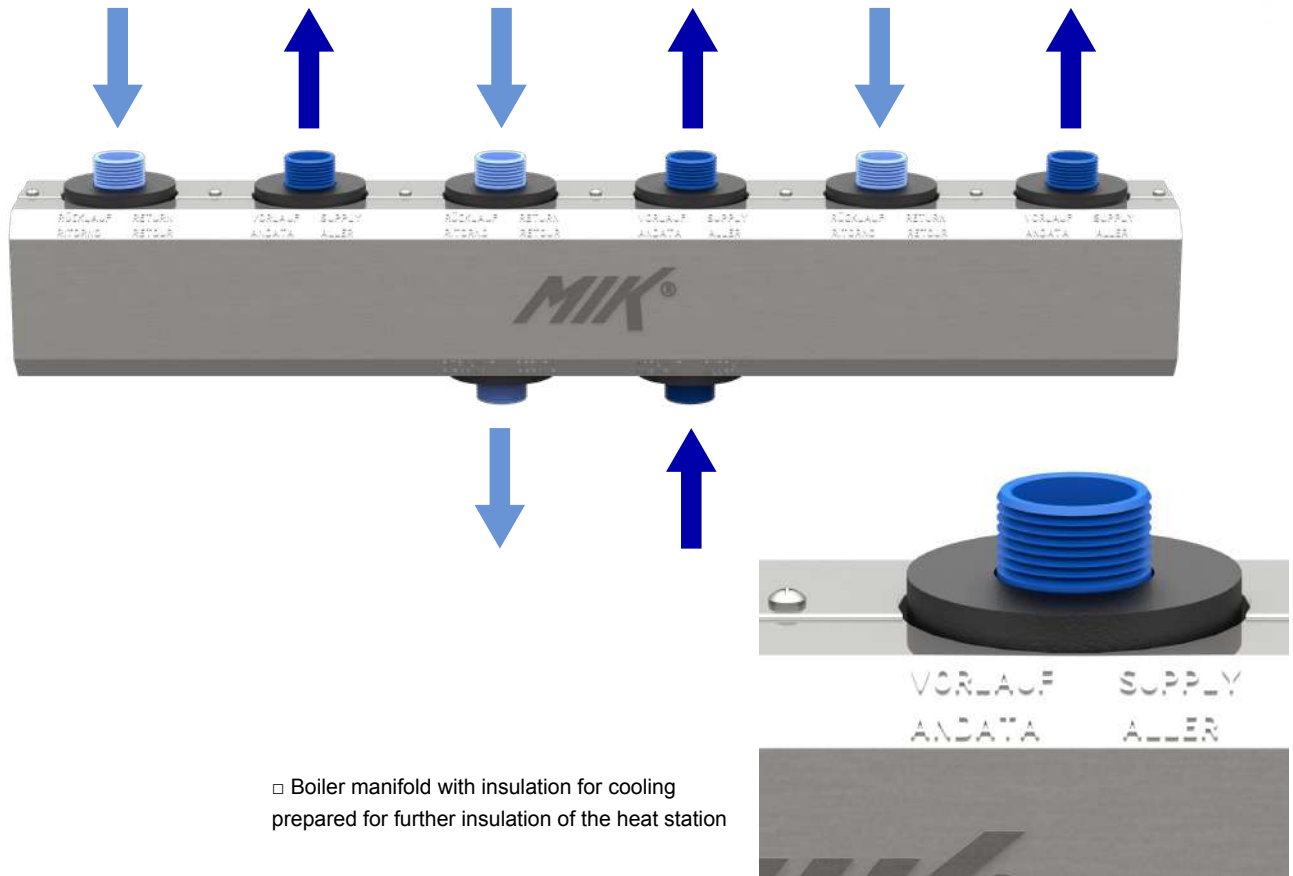

- Boiler manifold with insulation for cooling prepared for further insulation of the heat station

## Combined supply and return manifold HV

Up to 5980 kW output at the temperature difference of 20 °C and flow rate of 264,3 m<sup>3</sup>/h

- Material: S235 carbon steel
- Compact construction with integrated supply and return
- Supply and return connections located side by side
- Variable positions of boiler connections
- Consumer connections above and/or underneath
- Chambers filling/emptying connections with internal pipe thread
- Possible additional connections for temperature sensors/manometers
- Equipped with insulation and 1 mm galvanised sheet steel jacket with stamped supply and return markings
- Chambers coated with orange color zinc based primer (RAL 2004) acc. ISO 12944
- Manifold is pressure tested on 12 bars, max. working pressure 6 bar
- Equipped with wall brackets or stands

### Technical specification

Boiler connections	variable
Consumer connections	variable
Possible insulation:	
Polystyrene 25/35 mm	EPS 25/35 mm (EN 13501-1 E)
Max. working temperature <sub>EPS</sub>	90 °C
Vapour barrier	FEF 19 mm (EN 13501-1 B,s3,d0)
Max. working temperature <sub>FEF</sub>	85 °C
Rock wool 50/100 mm	MW-EN 13162-T6-WL(P)-AF30-SD20-CP5
Max. working temperature <sub>rock wool</sub>	110 °C
Max. working pressure	6 bar
Connections distance	variable
Produced acc.	2014/68/EU

Consumer connections:  
supply and return side by side

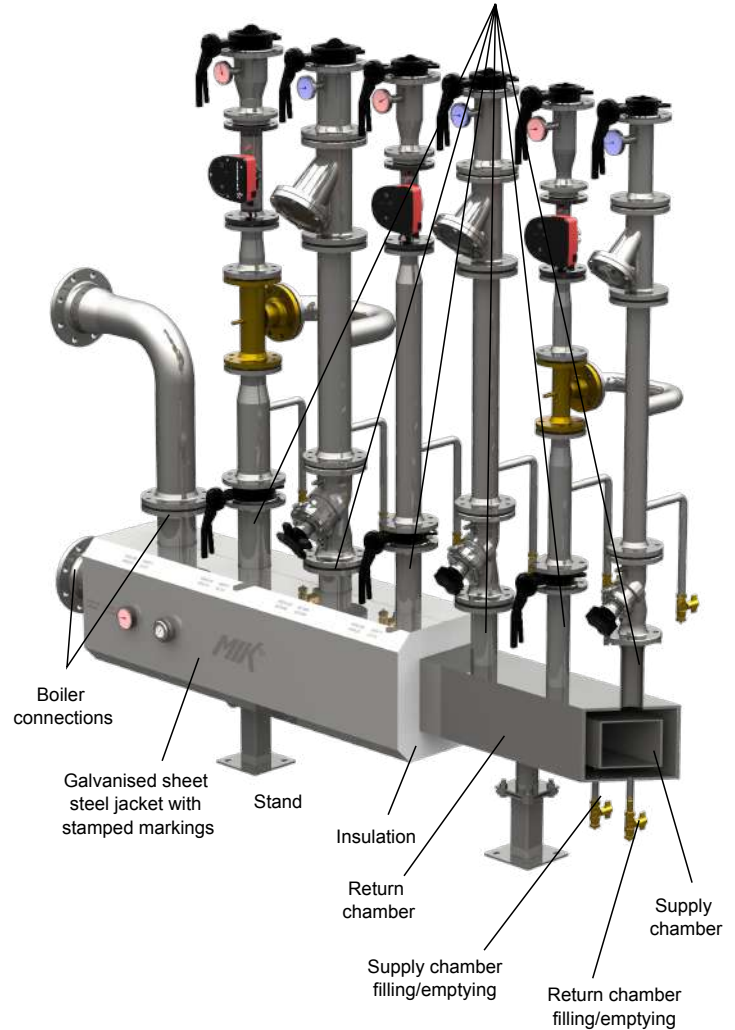

Type	Manifold connections size	Max. manifold connections size	Flow rate	Output at Δt=20°C
HV 60	DN32	DN40	3,3 m <sup>3</sup> /h	75 kW
HV 80	DN40	DN50	5,3 - 7,3 m <sup>3</sup> /h	120 - 165 kW
HV 100	DN50	DN65	8,5 - 11 m <sup>3</sup> /h	190 - 245 kW
HV 120	DN65	DN80	14 - 17,8 m <sup>3</sup> /h	315 - 400 kW
HV 160	DN80	DN100	19,3 - 31,8 m <sup>3</sup> /h	435 - 720 kW
HV 200	DN100	DN125	32,5 - 42 m <sup>3</sup> /h	735 - 950 kW
HV 250	DN125	DN150	49 - 71,8 m <sup>3</sup> /h	1110 - 1625 kW
HV 300	DN150	DN200	71,8 - 118 m <sup>3</sup> /h	1625 - 2675 kW
HV 350	DN200	DN250	121,5 - 138 m <sup>3</sup> /h	2750 - 3130 kW
HV 400	DN250	DN300	181,5 m <sup>3</sup> /h	4110 kW
HV 450	DN300	DN350	251,8 m <sup>3</sup> /h	5700 kW
HV 500	DN350	DN400	264,3 m <sup>3</sup> /h	5980 kW

### Maximum manifold connections are possible in the following configurations:

- The number of maximum connection sizes is limited to 2

SO

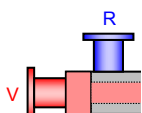

SU

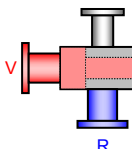

V

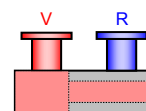



# Enquiry/order form: Combined supply and return manifold HV

Manifold size A	Manifold connections size	Max. manifold connections size	Flow rate	Output at $\Delta t=20^{\circ}\text{C}$
<input type="checkbox"/> 60	DN32	DN40	3,3 m <sup>3</sup> /h	75 kW
<input type="checkbox"/> 80	DN40	DN50	5,3 - 7,3 m <sup>3</sup> /h	120 - 165 kW
<input type="checkbox"/> 100	DN50	DN65	8,5 - 11 m <sup>3</sup> /h	190 - 245 kW
<input type="checkbox"/> 120	DN65	DN80	14 - 17,8 m <sup>3</sup> /h	315 - 400 kW
<input type="checkbox"/> 160	DN80	DN100	19,3 - 31,8 m <sup>3</sup> /h	435 - 720 kW
<input type="checkbox"/> 200	DN100	DN125	32,5 - 42 m <sup>3</sup> /h	735 - 950 kW
<input type="checkbox"/> 250	DN125	DN150	49 - 71,8 m <sup>3</sup> /h	1110 - 1625 kW
<input type="checkbox"/> 300	DN150	DN200	71,8 - 118 m <sup>3</sup> /h	1625 - 2675 kW
<input type="checkbox"/> 350	DN200	DN250	121,5 - 138 m <sup>3</sup> /h	2750 - 3130 kW
<input type="checkbox"/> 400	DN250	DN300	181,5 m <sup>3</sup> /h	4110 kW
<input type="checkbox"/> 450	DN300	DN350	251,8 m <sup>3</sup> /h	5700 kW
<input type="checkbox"/> 500	DN350	DN400	264,3 m <sup>3</sup> /h	5980 kW

Maximum manifold connections are possible in the following configurations:

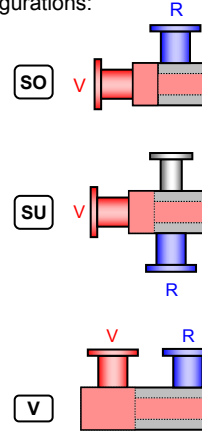

The number of maximum connection sizes is limited to 2.

Manifold length  mm

Max. operating pressure excess  bar

Max. temperature  °C

Insulation choice:

- Galvanised sheet steel jacket
  - polystyrene EPS 25 mm (EN 13501-1 E) - HV60 only
  - polystyrene EPS 35 mm (EN 13501-1 E) - HV80 only
  - rock wool (MW-EN 13162-T6-WL(P)-AF30-SD20-CP5)
    - 50 mm
    - 100 mm

- vapour barrier FEF 19 mm (EN 13501-1 B,s3,d0)

- \_\_\_\_\_

- Wall brackets

A =  mm

(For HV 80-120, A = 160 or 220 mm)

- Stands

H =  mm

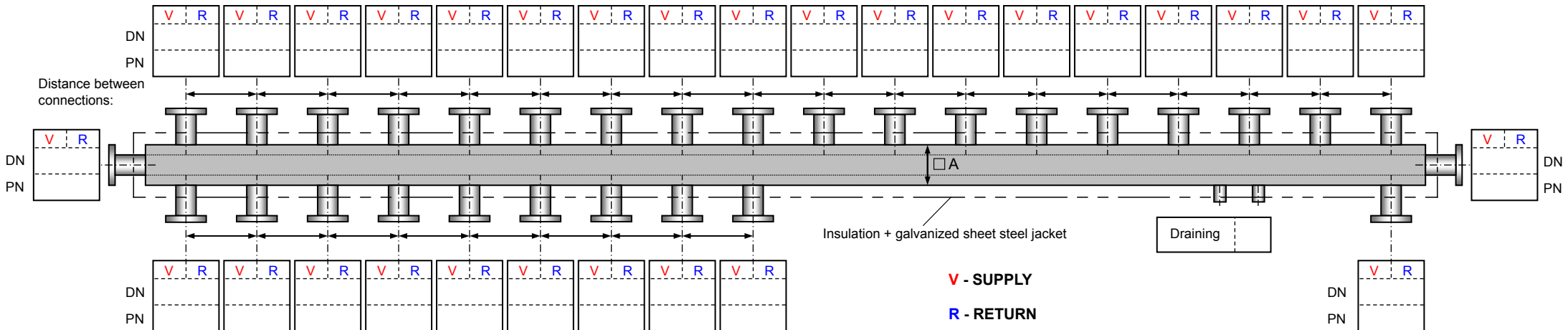
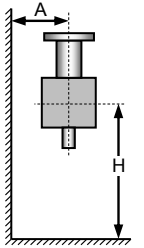

REMARKS:

## Combined supply and return manifold with intermediate insulation HVI

Up to 5955 kW output at the temperature difference of 20 °C and flow rate of 263 m<sup>3</sup>/h

- Material: S235 carbon steel
- Compact construction with integrated supply and return
- Supply and return chambers thermally separated
- Supply and return connections located side by side
- Variable positions of boiler connections
- Consumer connections above and/or underneath
- Chambers filling/emptying connections with internal pipe thread
- Possible additional connections for temperature sensors/manometers
- Equipped with insulation and 1 mm galvanised sheet steel jacket with stamped supply and return markings
- Chambers coated with orange color zinc based primer (RAL 2004) acc. ISO 12944
- Manifold is pressure tested on 12 bars, max. working pressure 6 bar
- Equipped with wall brackets or stands

### Technical specification

Boiler connections	variable
Consumer connections	variable
Possible insulation:	
Polystyrene 35 mm	EPS 35 mm (EN 13501-1 E)
Max. working temperature <sub>EPS</sub>	90 °C
Vapour barrier	FEF 19 mm (EN 13501-1 B,s3,d0)
Max. working temperature <sub>FEF</sub>	85 °C
Rock wool 50/100 mm	MW-EN 13162-T6-WL(P)-AF30-SD20-CP5
Max. working temperature <sub>rock wool</sub>	110 °C
Max. working pressure	6 bar
Connections distance	variable
Produced acc.	2014/68/EU

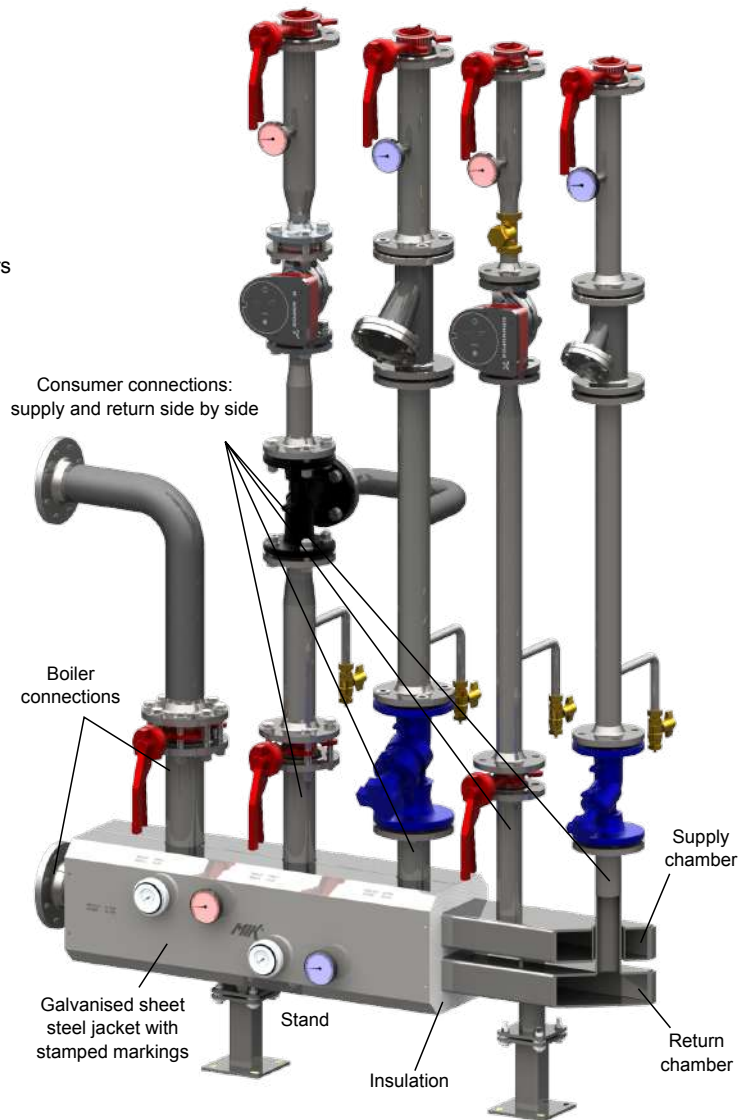

Type	Manifold connections size	Max. manifold connections size	Flow rate	Output at Δt=20°C
HVI 80	DN25	DN40	2,3 - 3,3 m <sup>3</sup> /h	50 - 75 kW
HVI 100	DN32	DN50	4 - 6,5 m <sup>3</sup> /h	90 - 150 kW
HVI 120	DN50	DN65	8,5 - 13 m <sup>3</sup> /h	190 - 290 kW
HVI 160	DN65	DN80	14 - 19,3 m <sup>3</sup> /h	315 - 435 kW
HVI 200	DN80	DN100	19,3 - 32 m <sup>3</sup> /h	435 - 725 kW
HVI 250	DN100	DN125	32 - 49 m <sup>3</sup> /h	725 - 1100 kW
HVI 300	DN125	DN200	49 - 86 m <sup>3</sup> /h	1100 - 1950 kW
HVI 400	DN150	DN200	71,8 - 120 m <sup>3</sup> /h	1625 - 2700 kW
HVI 500	DN200	DN300	120 - 263 m <sup>3</sup> /h	2700 - 5955 kW

### Maximum manifold connections are possible in the following configurations:

- The number of maximum connection sizes is limited to 2

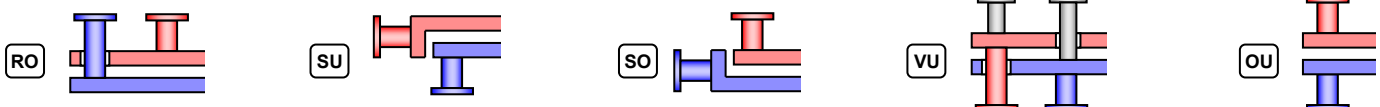



# Enquiry/order form: Combined supply and return manifold with intermediate insulation HVI

Manifold size A	Manifold connections size	Max. manifold connections size	Flow rate	Output at $\Delta t=20^{\circ}\text{C}$	Maximum manifold connections are possible in the following configurations:	Manifold length <input style="width: 80px;" type="text"/> mm
<input type="checkbox"/> 80	DN25	DN40	2,3 - 3,3 m <sup>3</sup> /h	50 - 75 kW	<p>The number of maximum connection sizes is limited to 2.</p>	Max. operating pressure excess <input style="width: 80px;" type="text"/> bar
<input type="checkbox"/> 100	DN32	DN50	4 - 6,5 m <sup>3</sup> /h	90 - 150 kW		Max. temperature <input style="width: 80px;" type="text"/> °C
<input type="checkbox"/> 120	DN50	DN65	8,5 - 13 m <sup>3</sup> /h	190 - 290 kW		Insulation choice:
<input type="checkbox"/> 160	DN65	DN80	14 - 19,3 m <sup>3</sup> /h	315 - 435 kW		<input type="checkbox"/> Galvanised sheet steel jacket
<input type="checkbox"/> 200	DN80	DN100	19,3 - 32 m <sup>3</sup> /h	435 - 725 kW		<input type="checkbox"/> polystyrene EPS 35 mm (EN 13501-1 E) - HVI80 only
<input type="checkbox"/> 250	DN100	DN125	32 - 49 m <sup>3</sup> /h	725 - 1100 kW		<input type="checkbox"/> rock wool (MW-EN 13162-T6-WL(P)-AF30-SD20-CP5)
<input type="checkbox"/> 300	DN125	DN200	49 - 86 m <sup>3</sup> /h	1100 - 1950 kW		<input type="checkbox"/> 50 mm <input type="checkbox"/> 100 mm
<input type="checkbox"/> 400	DN150	DN200	71,8 - 120 m <sup>3</sup> /h	1625 - 2700 kW		<input type="checkbox"/> vapour barrier FEF 19 mm (EN 13501-1 B,s3,d0)
<input type="checkbox"/> 500	DN200	DN300	120 - 263 m <sup>3</sup> /h	2700 - 5955 kW		<input type="checkbox"/> Wall brackets

A =  mm  
(For HVI 80-120, A = 160 or 220 mm)

Stands  
H =  mm

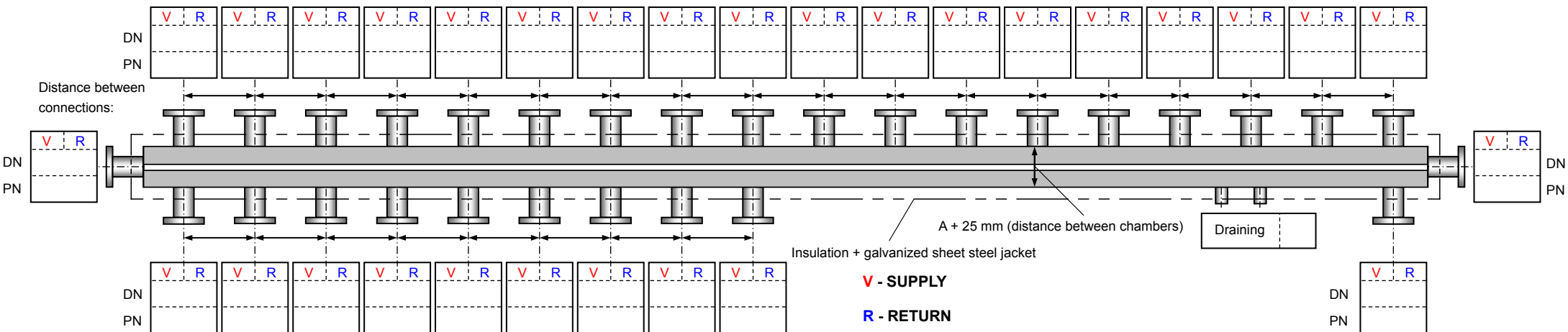

**REMARKS:**

## Single chamber manifold HVE

Up to 9845 kW output at the temperature difference of 20 °C and flow rate of 435 m<sup>3</sup>/h

Boiler supply manifold and return collector:

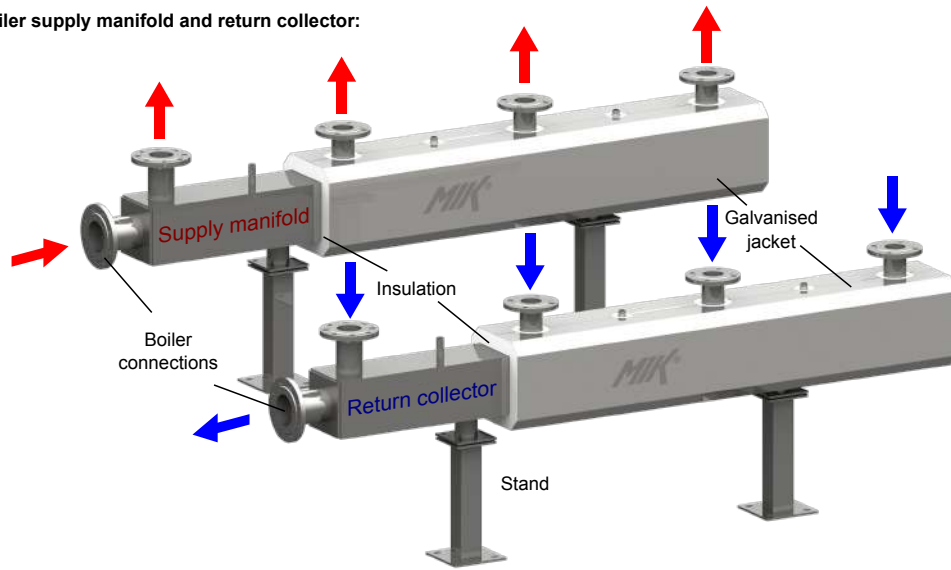

- Material: S235 carbon steel
- Variable positions of boiler connections
- Consumer connections above and/or underneath
- Chambers filling/emptying connections with internal pipe thread
- Possible additional connections for temperature sensors/manometers
- Equipped with insulation and 1 mm galvanised sheet steel jacket
- Chambers coated with orange color zinc based primer (RAL 2004) acc. ISO 12944
- Manifold is pressure tested on 12 bars, max. working pressure 6 bar
- Equipped with wall brackets or stands

### Technical specification

Boiler connections	variable
Consumer connections	variable
Possible insulation:	
Polystyrene 35 mm	EPS 35 mm (EN 13501-1 E)
Max. working temperature <sub>EPS</sub>	90 °C
Vapour barrier	FEF 19 mm (EN 13501-1 B,s3,d0)
Max. working temperature <sub>FEF</sub>	85 °C
Rock wool 50/100 mm	MW-EN 13162-T6-WL(P)-AF30-SD20-CP5
Max. working temperature <sub>rock wool</sub>	110 °C
Max. working pressure	6 bar
Connections distance	variable
Produced acc.	2014/68/EU

Type	Manifold connections size	Flow rate	Output at Δt=20°C
HVE 80	DN50	8,5 m <sup>3</sup> /h	195 kW
HVE 100	DN65	14 m <sup>3</sup> /h	315 kW
HVE 120	DN80	19,3 m <sup>3</sup> /h	435 kW
HVE 160	DN125	49 m <sup>3</sup> /h	1110 kW
HVE 200	DN150	71,8 m <sup>3</sup> /h	1625 kW
HVE 250	DN200	121,5 m <sup>3</sup> /h	2750 kW
HVE 300	DN250	191,8 m <sup>3</sup> /h	4340 kW
HVE 350	DN300	271,3 m <sup>3</sup> /h	6140 kW
HVE 400	DN300	271,3 m <sup>3</sup> /h	6140 kW
HVE 450	DN350	329,5 m <sup>3</sup> /h	7460 kW
HVE 500	DN400	435 m <sup>3</sup> /h	9845 kW



# Enquiry/order form: Single chamber manifold HVE

Manifold size A	Manifold connections size	Flow rate	Output at $\Delta t=20^{\circ}\text{C}$
<input type="checkbox"/> 80	DN50	8,5 m <sup>3</sup> /h	195 kW
<input type="checkbox"/> 100	DN65	14 m <sup>3</sup> /h	315 kW
<input type="checkbox"/> 120	DN80	19,3 m <sup>3</sup> /h	435 kW
<input type="checkbox"/> 160	DN125	49 m <sup>3</sup> /h	1110 kW
<input type="checkbox"/> 200	DN150	71,8 m <sup>3</sup> /h	1625 kW
<input type="checkbox"/> 250	DN200	121,5 m <sup>3</sup> /h	2750 kW
<input type="checkbox"/> 300	DN250	191,8 m <sup>3</sup> /h	4340 kW
<input type="checkbox"/> 350	DN300	271,3 m <sup>3</sup> /h	6140 kW
<input type="checkbox"/> 400	DN300	271,3 m <sup>3</sup> /h	6140 kW
<input type="checkbox"/> 450	DN350	329,5 m <sup>3</sup> /h	7460 kW
<input type="checkbox"/> 500	DN400	435 m <sup>3</sup> /h	9845 kW

Manifold length  mm

Max. operating pressure excess  bar

Max. temperature  °C

Insulation choice:

Galvanised sheet steel jacket

polystyrene EPS 35 mm (EN 13501-1 E) - HVE80 only

rock wool (MW-EN 13162-T6-WL(P)-AF30-SD20-CP5)

50 mm     100 mm

vapour barrier FEF 19 mm (EN 13501-1 B,s3,d0)

\_\_\_\_\_

Wall brackets

A =  mm

(For HVE 80-120, A = 160 or 220 mm)

Stands

H =  mm

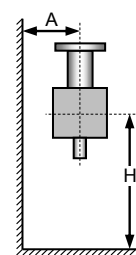
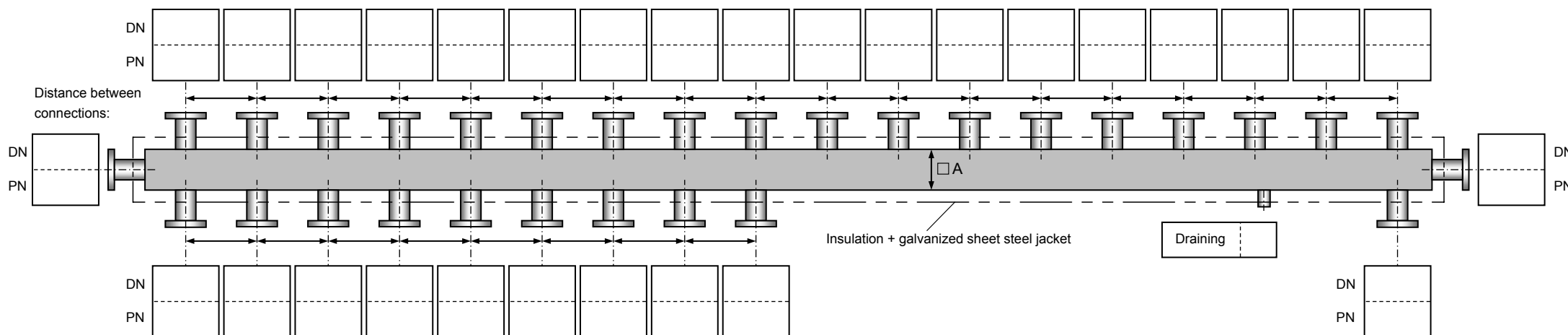



REMARKS:

## Hydraulic separators HW

Up to 6790 kW output at the temperature difference of 20 °C and flow rate of 300 m<sup>3</sup>/h

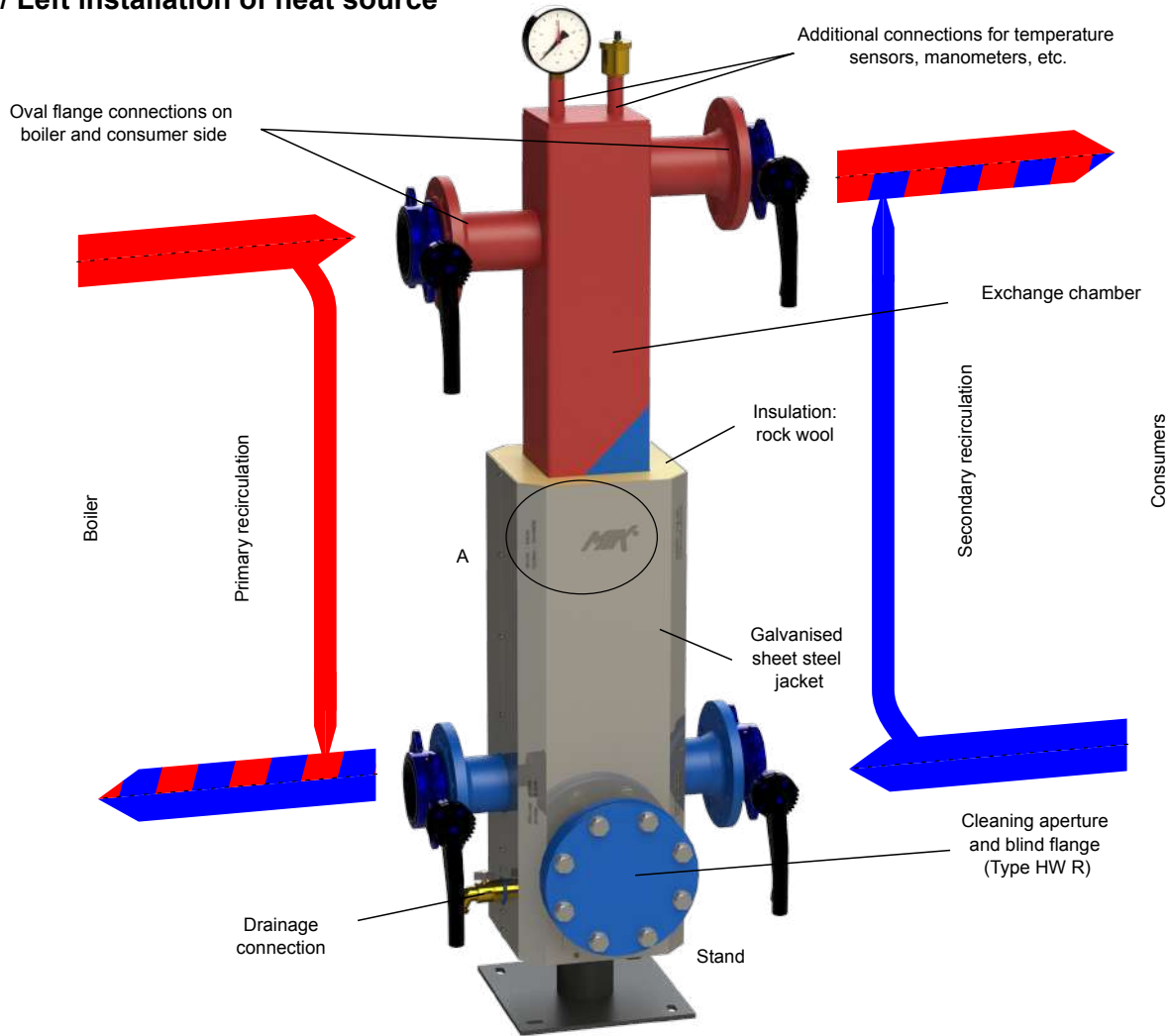
### Heating / Left installation of heat source



**Detail A:**  
Supply and return markings stamped into sheet steel jacket



### Cooling / Right installation of heat pump

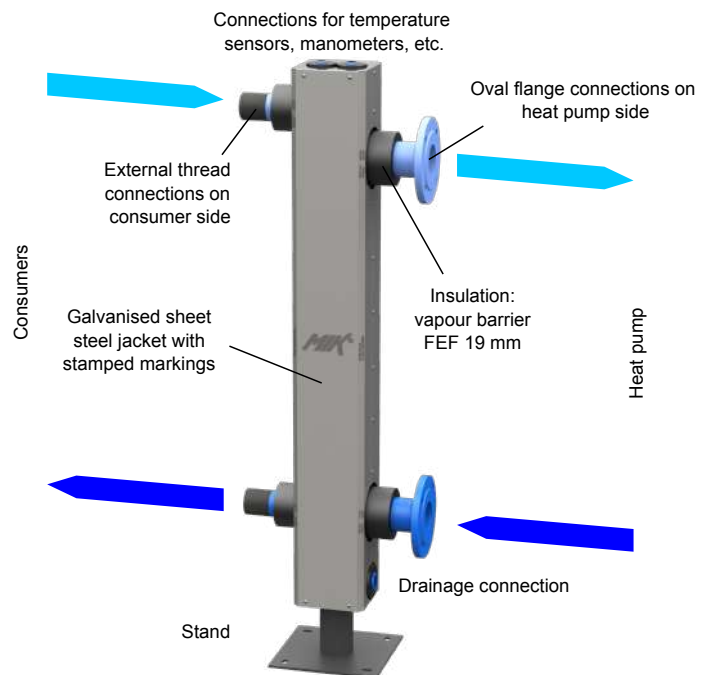



- Material: S235 carbon steel
- Side connections for facing boiler and collector circuits
- Offset connections for improved bleeding
- Variable connection types possible (oval flanges/ threaded connection)
- Internal pipe thread connections for bleeding, temperature sensor and drainage
- Separator is anti-corrosion protected with primer
- Equipped with insulation for heating or cooling and 1 mm galvanised sheet steel jacket with stamped supply/return and boiler/consumer markings
- Insulation for heating: rock wool 50/100 mm (MW-EN 13162-T6-WL(P)-AF30-SD20-CP5)
- Insulation for cooling: vapour barrier FEF 19 mm acc. EN 13501-1 B,s3,d0
- Separator is pressure tested on 12 bars, max. working pressure 6 bar
- Possible variants:
  - Hydraulic separator without cleaning aperture HW
  - Hydraulic separator with cleaning aperture HW R

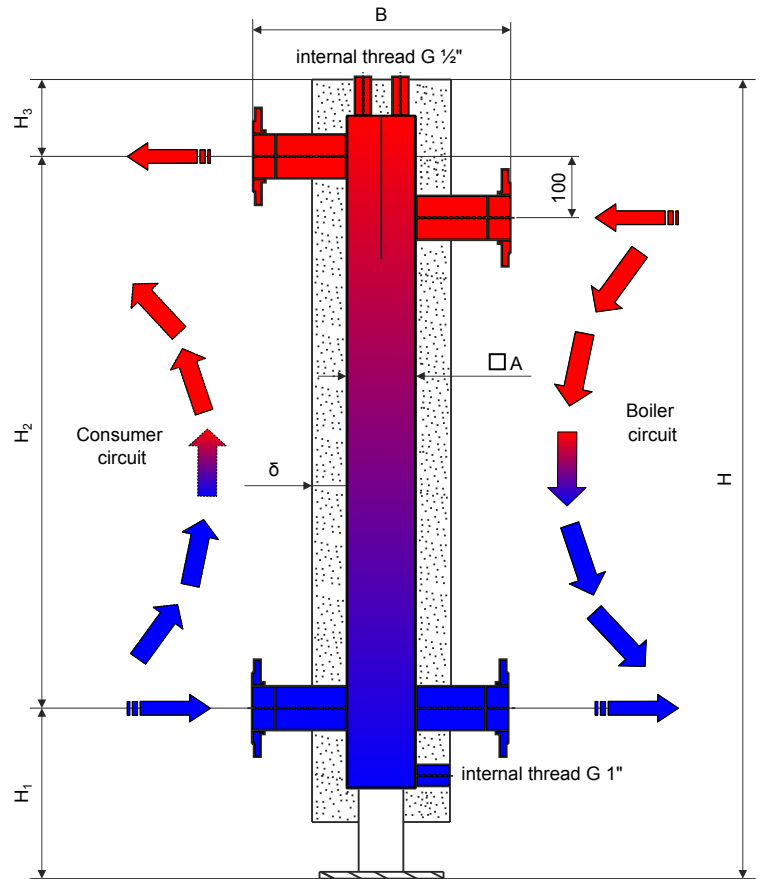

Type	Capacity		Connections size	Dimensions							Cleaning aperture	Volume [l]	Code
	Flow rate [m <sup>3</sup> /h]	Output at Δt=20°C [kW]		A [mm]	B [mm]	H [mm]	H <sub>1</sub> [mm]	H <sub>2</sub> [mm]	H <sub>3</sub> [mm]	δ [mm]			
HW 100	9	205	DN50/PN6	100	400	950	335	500	115	50	-	8	600 100
HW 100 R	9	205	DN50/PN6	100	400	950	335	500	115	50	DN65	8	600 100 R
HW 120	12	270	DN65/PN6	120	420	1370	345	900	125	50	-	18	600 120
HW 120 R	12	270	DN65/PN6	120	420	1370	345	900	125	50	DN80	18	600 120 R
HW 160	20	445	DN80/PN6	160	460	1448	363	950	135	50	-	28	600 160
HW 160 R	20	445	DN80/PN6	160	460	1448	363	950	135	50	DN125	28	600 160 R
HW 200	28	630	DN100/PN6	200	500	1538	378	1000	160	50	-	50	600 200
HW 200 R	28	630	DN100/PN6	200	500	1538	378	1000	160	50	DN150	50	600 200 R
HW 250	43	975	DN125/PN6	250	750	1648	438	1000	210	100	-	78	600 250
HW 250 R	43	975	DN125/PN6	250	750	1648	438	1000	210	100	DN200	78	600 250 R
HW 300	64	1445	DN150/PN6	300	800	1690	460	1000	230	100	-	120	600 300
HW 300 R	64	1445	DN150/PN6	300	800	1690	460	1000	230	100	DN200	120	600 300 R
HW 350	93	2095	DN200/PN6	350	850	1816	544	1000	272	100	-	193	600 350
HW 350 R	93	2095	DN200/PN6	350	850	1816	544	1000	272	100	DN200	193	600 350 R
HW 400	126	2855	DN250/PN6	400	900	2000	605	1100	295	100	-	281	600 400
HW 400 R	126	2855	DN250/PN6	400	900	2000	605	1100	295	100	DN200	281	600 400 R
HW 450	169	3825	DN250/PN6	450	950	2000	605	1100	295	100	-	342	600 450
HW 450 R	169	3825	DN250/PN6	450	950	2000	605	1100	295	100	DN200	342	600 450 R
HW 500	213	4830	DN300/PN6	500	1000	2170	640	1200	330	100	-	450	600 500
HW 500 R	213	4830	DN300/PN6	500	1000	2170	640	1200	330	100	DN200	450	600 500 R
HW 600	300	6790	DN350/PN6	600	1100	2450	700	1400	350	100	-	670	600 600
HW 600 R	300	6790	DN350/PN6	600	1100	2450	700	1400	350	100	DN200	670	600 600 R

**Wall Bracket L-HV 100-150 (840009) is replaced with new Wall Bracket LU-HV 100-150 (840012)**

Old Bracket L-HV 100-150

Code: 840009

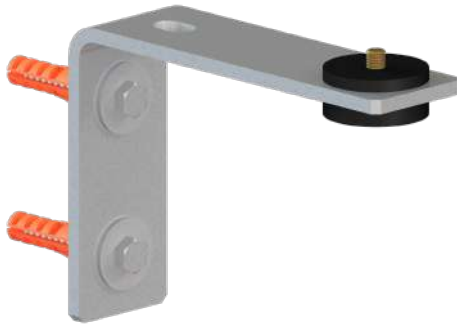

New Bracket LU-HV 100-150

Code: 840012



- higher load capacity,
- new damping element,
- new design,

**Wall Bracket WK 80-160 (840010) and WK 80-220 (840011) are replaced with new Wall Bracket LU-HV 160-220 (840013)**

Old Bracket: WK 80-160 (WK 80-220)

Code: 840010 (840011)



-screw M10 for supports

New Bracket LU-HV 160-220

Code: 840013



-screw M8 for supports

**Adjustable stand SKL**

Adjustable stands SKL with screw M10, now comes with new damping element that has screw M8 which fits on a boiler manifold with new supports.

Code remains the same: 840 015 (450-660 mm)

840 016 (650-900 mm)



Old supports on manifold  
Old Brackets

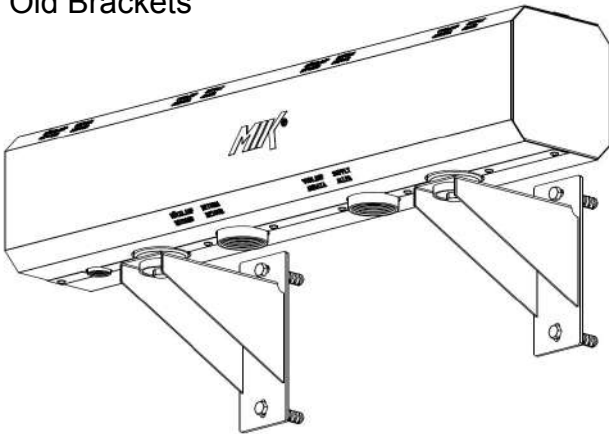

New supports on manifold  
New Brackets

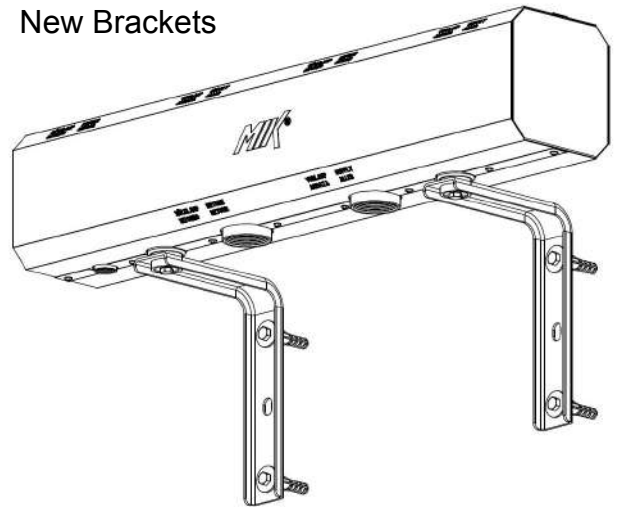

Old Brackets: **WK 80-160** (WK 80-220)  
Code: **840010** (840011)

New Bracket: **LU-HV 160-220**  
Code: **840013**

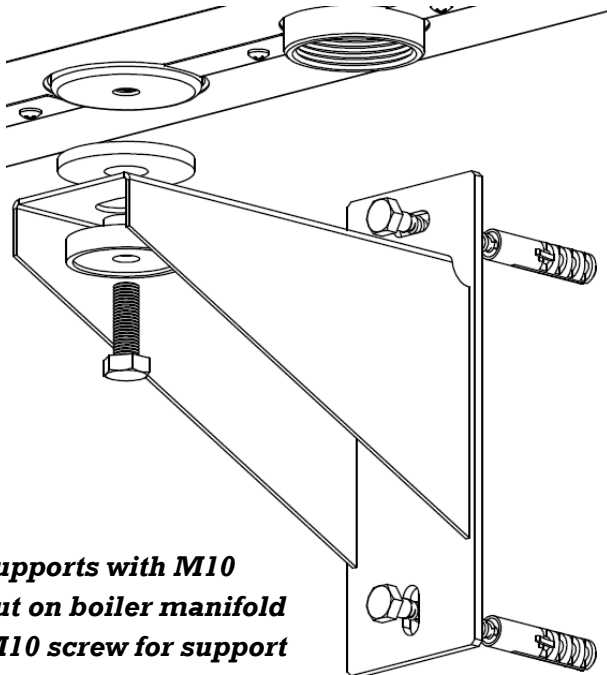

**-supports with M10  
nut on boiler manifold  
-M10 screw for support**

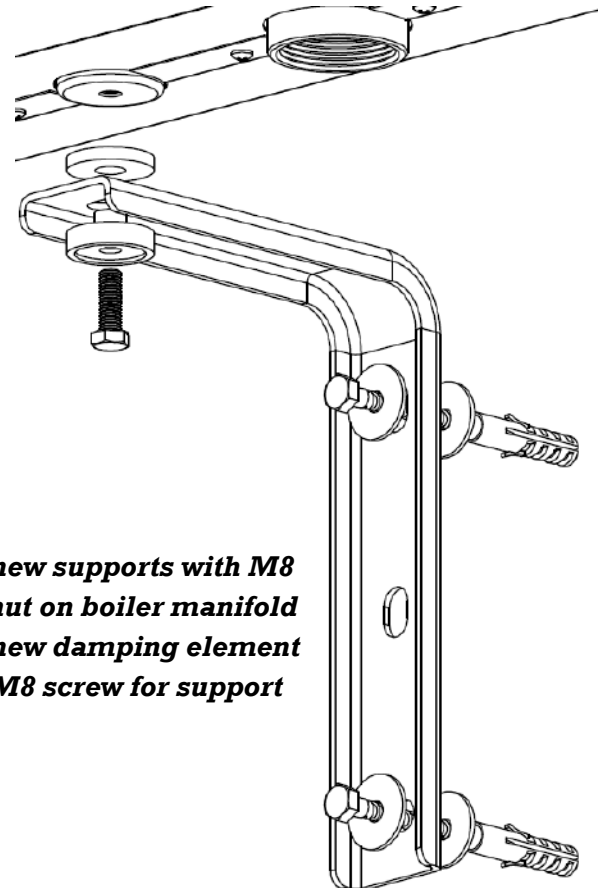

**-new supports with M8  
nut on boiler manifold  
-new damping element  
-M8 screw for support**

New Bracket **LU-HV 160-220** (840013), replaces brackets WK 80-160 (840010) and WK 80-220 (840011) on boiler manifold types:

<b>HVI</b>	<b>HV 80/200</b>
<b>HV 80/125</b>	<b>HV 80/200 SU</b>
<b>HV 80/125/190-DN25</b>	

Additionally, on mentioned types of boiler manifolds, **adjustable stands SKL** will come with new damping element that has screw **M8** which fits on manifolds with new supports.

MBI GmbH - the primary distribution partner of the MIK products on the european market  
Export stake over 90%



Dealer:

MARING d.o.o.  
Livadarska 53  
HR-40305 Nedelišće  
Croatia  
Tel.: +385 (0) 40 821 551  
Fax: +385 (0) 40 821 446

REMOTE PLANT ČAKOVEC  
Zagrebačka ulica 38  
HR-40000 Čakovec  
Croatia  
Tel.: +385 (0) 40 638 638  
Fax: +385 (0) 40 638 639