

# HYDRAULIC SEPARATORS

**HW 60/250**  
**HW 80/400**

**up to 2 m<sup>3</sup>/h**  
**up to 5 m<sup>3</sup>/h**

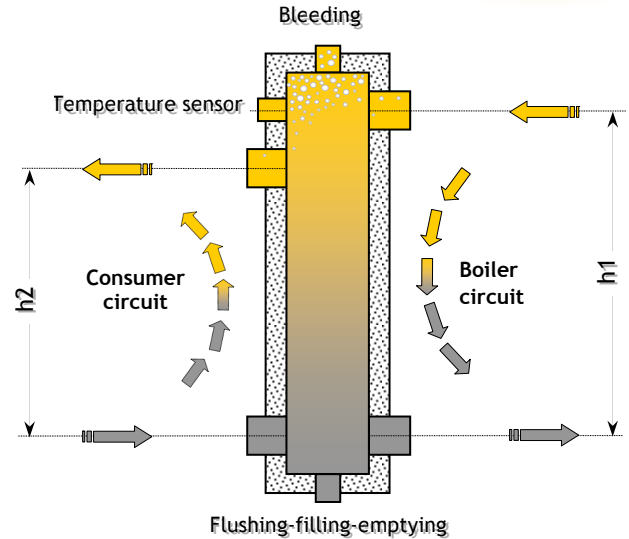
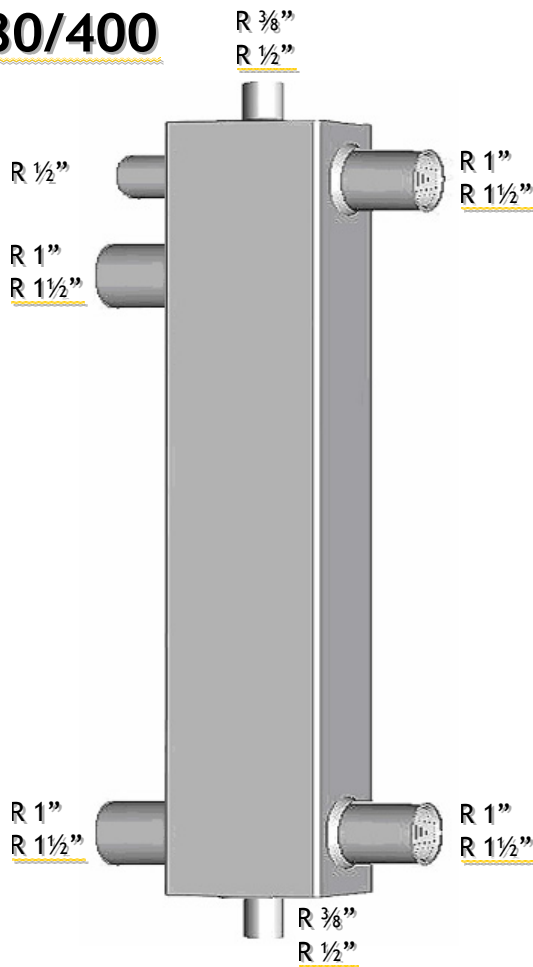

- ❑ Exchange chamber made of 60x60 or 80x80 square tube
- ❑ Connections: R 1" or R 1 1/2" couplings
- ❑ Upper coupling for bleeding connection and lower connection for flushing-filling-emptying
- ❑ R 1/2" coupling for temperature sensor
- ❑ Hydraulic separator is galvanised and factory-tested to 12 bar pressure
- ❑ Max. operating pressure 6 bar
- ❑ Max. supply temperature 90 °C
- ❑ Insulated with galvanised sheet steel jacket:
  - galvanised sheet steel jacket
  - 25 mm insulation to DIN 4102-B2 standard

## Hydraulic separator HW 60/250 and HW 80/400

**MIK** Hydraulic separator with insulation



- ❑ Exchange chamber made of 60x60 or 80x80 square tube
- ❑ Connections: R 1" or R 1 1/2" couplings
- ❑ Upper coupling for bleeding connection and lower connection for flushing-filling-emptying
- ❑ 25 mm insulation to DIN 4102-B2 standard with galvanised sheet steel jacket

Type	Max. flow rate	Dimensions h1, h2 [mm]	Insul.	Product No.
<b>HW 60/250</b>	2 m <sup>3</sup> /h	250, 200	25 mm	<b>850 009</b>
<b>HW 80/400</b>	5 m <sup>3</sup> /h	420, 340	35 mm	<b>850 010</b>

Mounting suggestion:

**MIK** Wall mountings for insulated separator

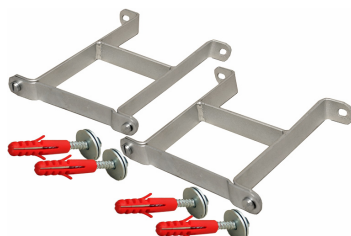

- ❑ Offset 100, 150, 160 or 220 mm to middle of hydraulic separator
- ❑ Galvanised
- ❑ Including screws and wall plugs
- ❑ Pack contents: 2 pieces

Type		Offset to middle of hydraulic separator	Product No.
<b>H-HV 100</b>	for HW 60	100 mm	<b>840 007</b>
<b>H-HV 150</b>		150 mm	<b>840 008</b>
<b>H-HW 160</b>	for HW 80	160 mm	<b>850 101</b>
<b>H-HW 220</b>		220 mm	<b>850 102</b>